

NECCHI

Instruction Manual

C700

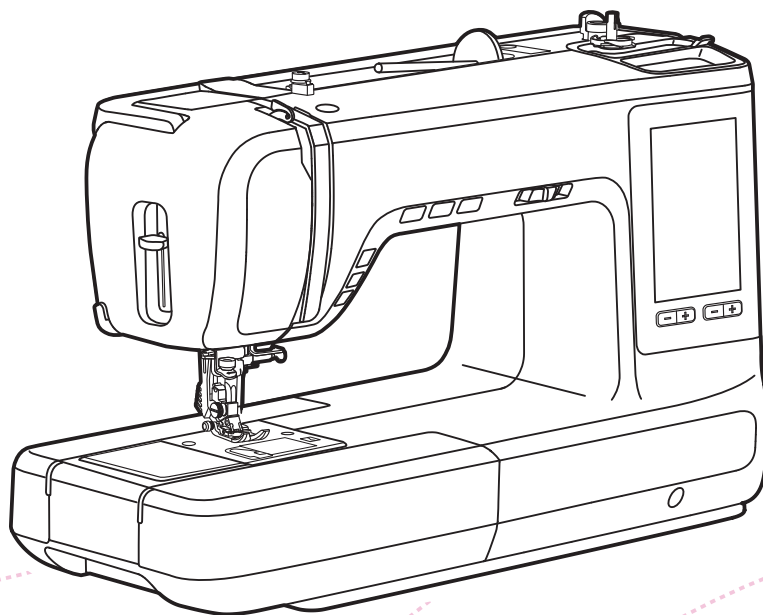

NecchiAIO

Enjoy your Necchi time!



Important safety instructions

When using an electrical appliance, basic safety should always be followed, including the following:

Read all instructions before using this sewing machine.

DANGER - To reduce the risk of electric shock:

1. An appliance should never be left unattended when plugged in.
2. Always unplug this appliance from the electric outlet immediately after using and before cleaning.

WARNING - To reduce the risk of burns, fire, electric shock, or injury to persons:

1. Read the instruction carefully before you use the machine
2. Keep the instructions at a suitable place close to the machine and hand it over if you give the machine to a third party.
3. Use the machine only in dry locations.
4. Never leave the machine unattended with children or elderly people as they may not be able to estimate the risk.
5. This appliance can be used by children aged from 8 years and above and persons with reduced physical, sensory or mental capabilities or lack of experience and knowledge if they have been given supervision or instruction concerning use of the appliance in a safe way and understand the hazards involved.
6. Children shall not play with the appliance.
7. Cleaning and user maintenance shall not be made by children without supervision.
8. Always switch off the machine if you carry out preparation for work (change the needle, feed the yarn through the machine, change the footer, etc.).
9. Always unplug the machine if you leave it unattended, to avoid injury by expediently switch on the machine.
10. Always unplug the machine if you carry out maintenance (oiling, cleaning).
11. Don't use the machine if it's wet or in humid environment.
12. Never pull at the cord, always unplug the machine by gripping the plug.
13. If the LED lamp is damaged or broken, it must be replaced by the manufacturer or it's service agent or a similarly qualified person, in order to avoid a hazard.
14. Never place anything on the pedal.

15. Never use the machine if the air vents are blocked, keep the air vents of the machine and the foot pedal free from dust, fusel and leftovers.
16. The machine must only be used with designated foot controller, in order to avoid a hazard. If the foot controller is damaged or broken, it must be replaced by the manufacturer or its service agent or a similarly qualified person.
17. The sound pressure level at normal operation is smaller than 80dB(A).
18. Do not dispose of electrical appliances as unsorted municipal waste, use separate collection facilities.
19. Contact your local government for information regarding the collection systems available.
20. If electrical appliances are disposed of in landfills or dumps, hazardous substances can leak into the groundwater and get into the food chain, damaging your health and well-being.
21. When replacing old appliances with new ones, the retailer is legally obligated to take back your old appliance for disposal at least for free of charge.
22. The appliance is not to be used by persons (including children) with reduced physical, sensory or mental capabilities, or lack of experience and knowledge, unless they have been given supervision or instruction. (For outside Europe)
23. Children being supervised not to play with the appliance. (For outside Europe)

SAVE THESE INSTRUCTIONS

This sewing machine is intended for household use only.

Be sure to use the sewing machine in the temperature range from 5°C to 40°C. If the temperature is excessively low, the machine can fail to operate normally.

To carry the sewing machine, hold the carrying handle with your hand, and support the sewing machine with the other hand.

Contents

Machine Introduction

| | |
|---|----------|
| Principal parts of the machine | 2 |
| Front overview..... | 2 |
| Top overview | 3 |
| Back overview | 3 |
| Accessories | 4 |
| Using the accessory box | 5 |
| Connecting machine to power source | 6 |
| Polarized plug information | 6 |
| Foot control | 6 |

Machine Setup

| | |
|--|-----------|
| Sewing table | 8 |
| Free arm..... | 8 |
| Using the extension table | 8 |
| Two-step presser foot lifter | 9 |
| Using the knee lifter | 9 |
| Dual feed system (DFS) | 10 |
| To engage the DFS | 10 |
| To disengage the DFS | 11 |
| Fabric positioning | 11 |
| Using the thread net | 12 |
| Winding the bobbin | 13 |
| Inserting the bobbin | 15 |
| Threading the upper thread | 16 |
| Bringing up the bobbin thread | 20 |
| Replacing the needle | 21 |
| Matching needle/fabric/thread | 22 |
| Changing the presser foot | 23 |
| Remove the presser foot..... | 23 |
| Attach the presser foot..... | 23 |
| Remove and insert the presser foot holder..... | 23 |
| Insert the edge/quilting guide..... | 23 |
| Replacing the needle plate | 24 |
| To raise or drop the feed dogs | 25 |
| Operation buttons | 26 |

Instruction

| | |
|---|-----------|
| LCD screen | 31 |
| Home page..... | 31 |
| Function buttons and icon..... | 32 |
| Settings | 33 |
| Sewing setting..... | 33 |
| Machine setting..... | 35 |
| Selecting stitch | 40 |
| Introduction of sewing mode screen..... | 40 |
| Selecting stitch..... | 40 |
| Altering stitch | 42 |
| Altering the stitch width..... | 42 |

| | |
|---|-----------|
| Altering the stitch length..... | 42 |
| Altering the thread tension..... | 43 |
| Changing needle position | 44 |
| Setting stitch | 45 |
| Mirror..... | 45 |
| Elongation | 46 |
| Density | 46 |
| Balance calibration on current stitch pattern | 47 |
| Reverse sewing..... | 47 |
| Initial auto-lock..... | 48 |
| Pattern unit sewing..... | 48 |
| Stitch cycling setting | 48 |
| My favorite program | 49 |
| Save pattern..... | 49 |
| Overwrite pattern | 49 |
| Recall pattern | 49 |
| Delete pattern..... | 50 |
| Combination mode | 51 |
| Combine patterns..... | 51 |
| Add patterns..... | 51 |
| Delete patterns..... | 52 |
| Combination setting | 52 |
| Instructions to set combination patterns..... | 53 |
| Creating your own combination pattern..... | 54 |
| Save combination patterns | 54 |
| Overwrite combination patterns..... | 54 |
| Recall combination patterns | 55 |
| Delete combination patterns | 55 |
| Creating your own pattern | 56 |
| Edit mode icon introduction | 56 |
| Creating your own pattern..... | 57 |
| Pattern design screen..... | 57 |
| Using Grid to create a pattern..... | 58 |
| Move stitch point | 58 |
| Insert needle point | 59 |
| Duplicate needle point | 59 |
| Delete needle point | 60 |
| Triple stitch sewing..... | 60 |
| Undo/Redo..... | 61 |
| Save Creating pattern to My Favorite | 61 |

Stitch Chart

| | |
|---------------------------|-----------|
| Stitch chart | 63 |
| Utility | 63 |
| Buttonholes | 63 |
| Quliting | 63 |
| Satin | 63 |
| Decorative_Satin..... | 64 |
| Cross..... | 64 |
| Florals..... | 64 |
| Ornamental | 64 |

| | |
|------------------------------|----|
| Novelty | 65 |
| Alphabet-block style | 65 |
| Alphabet-script style | 65 |
| Alphabet-outline style | 66 |
| Alphabet-Russian style | 66 |

Sewing Basics

| | |
|------------------------------|-----------|
| Starting to sew | 68 |
| Useful skills | 70 |
| Reverse sewing..... | 70 |
| Sewing curves..... | 70 |
| Sewing corners | 71 |
| Sewing stretch fabrics..... | 71 |
| Sewing thin fabrics..... | 72 |
| Sewing heavy fabric..... | 72 |

Utility Stitches

| | |
|---|-----------|
| Automatic lock stitch..... | 74 |
| Stretch stitch | 75 |
| Straight stretch stitch | 75 |
| Zigzag stretch stitch | 75 |
| Sewing stretch fabrics and elastic tape | 76 |
| Overcasting stitch..... | 77 |
| Using the all purpose foot | 77 |
| Using the overcasting foot | 77 |
| Blind Hem | 78 |
| Buttonhole stitch | 79 |
| Making a buttonhole on stretch fabrics..... | 82 |
| Bar tack stitch | 84 |
| Darning stitch..... | 85 |
| Eyelet stitch | 87 |
| Button sewing | 88 |
| Zipper insertion..... | 89 |
| Inserting a centered zipper | 89 |
| Inserting a side zipper..... | 90 |
| Satin stitch sewing | 91 |
| Gathering | 92 |
| Gathered fabric | 92 |
| To gather and attach gathered fabric in one step | 92 |
| Smocking | 93 |
| Free motion darning, embroidery and monogramming | 94 |
| Preparation for embroidering and monogramming..... | 94 |
| Darning..... | 95 |
| Embroidery..... | 95 |
| Monogramming | 95 |
| Free motion | 96 |
| Open toe foot | 96 |
| Quilting..... | 97 |
| Using the edge/quilting guide..... | 97 |
| Joining the pieces of the fabric | 97 |

| | |
|---|------------|
| Patchwork stitching | 98 |
| Non-stick foot | 98 |
| Applique | 99 |
| Fagoting | 99 |
| Scallop stitch..... | 100 |
| Scallop edging..... | 100 |
| Scallop hem | 100 |
| Cording..... | 101 |
| Single cording | 101 |
| Striple cording | 101 |
| Narrow hemming..... | 102 |
| Invisible zipper application | 103 |
| Twin needle..... | 104 |

Maintenance and Trouble Shooting

| | |
|-------------------------------------|------------|
| Maintenance | 107 |
| Clean the machine surface | 107 |
| Clean the hook | 107 |
| Warning Function..... | 108 |
| Warning beeping sound | 108 |
| Trouble shooting guide | 109 |



Machine Introduction

Principal parts of the machine

Front overview

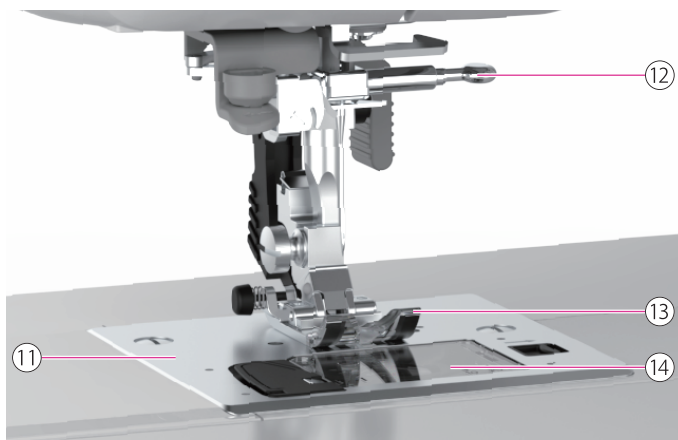
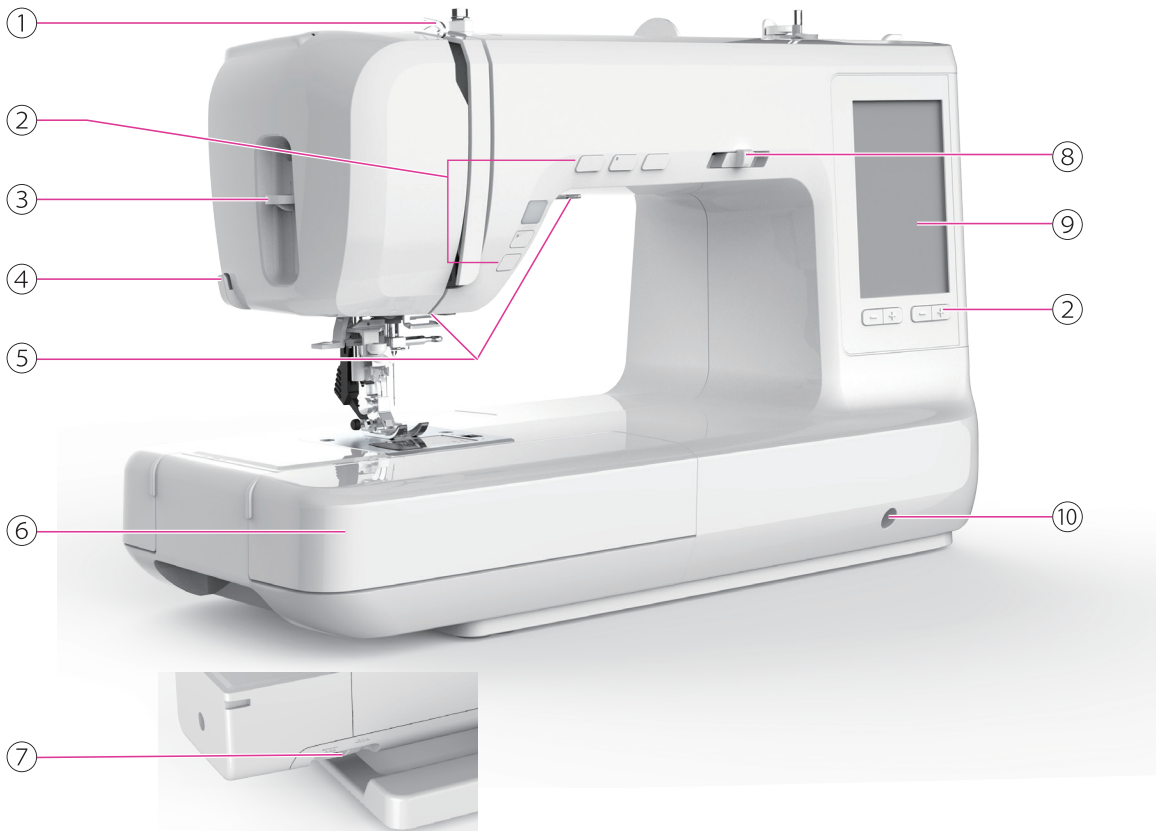

- ① Take-up lever
- ② Operation buttons
- ③ Automatic needle threader lever
- ④ Thread cutter
- ⑤ Sewing light
- ⑥ Sewing table and accessory box
- ⑦ Drop feed lever
- ⑧ Speed adjustment slider
- ⑨ LCD screen (touch panel)
- ⑩ Knee lifter slot
- ⑪ Needle plate
- ⑫ Needle clamp screw
- ⑬ Presser foot
- ⑭ Bobbin cover

Top overview



- ① Horizontal spool pin
- ② Upper thread guide
- ③ Bobbin thread guide
- ④ Second spool pin hole
- ⑤ Bobbin winder switch

- ⑥ Bobbin winder seat
- ⑦ Bobbin thread cutter
- ⑧ Magnet

Back overview

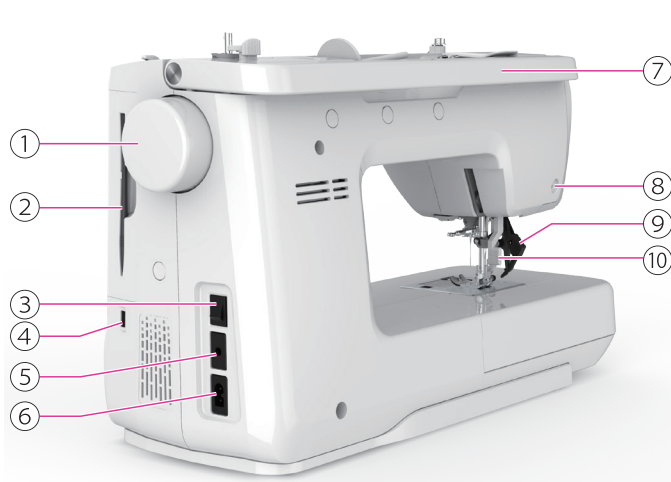

- ① Handwheel
- ② Stylus
- ③ Main power switch
- ④ USB port (Only for machine update)
- ⑤ Foot control connector
- ⑥ Power cord socket
- ⑦ Handle
- ⑧ Electronic buttonhole foot socket
- ⑨ Dual-feed system (DFS)
- ⑩ Presser foot lifter

Accessories

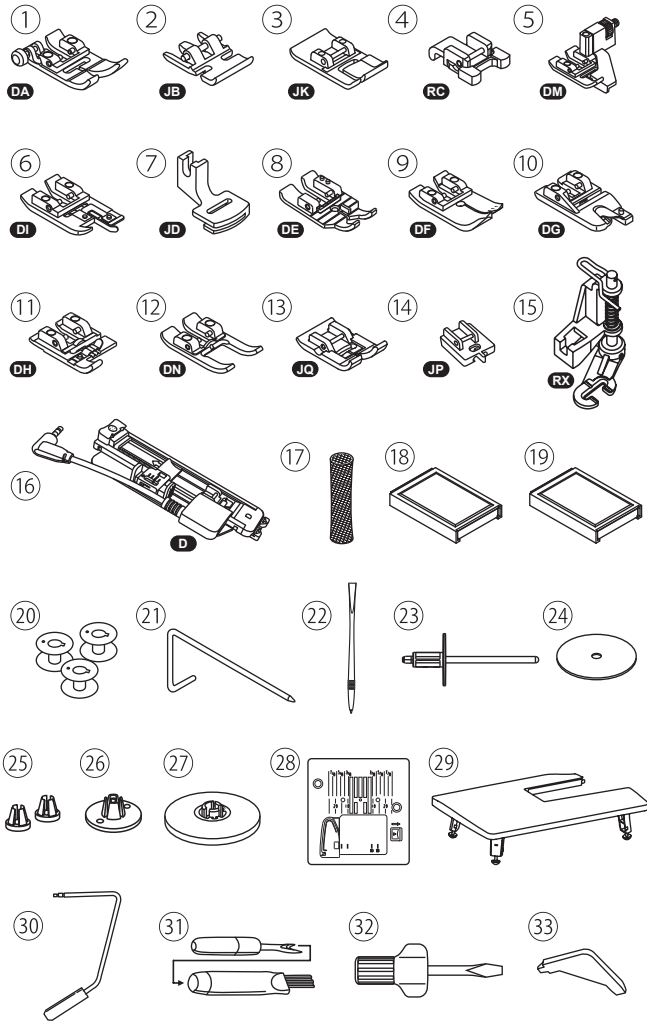

- ① All purpose foot
- ② Zipper foot
- ③ Satin stitch foot
- ④ Button sewing foot
- ⑤ Blind hem foot
- ⑥ Overcasting foot
- ⑦ Gathering foot
- ⑧ 1/4" Quilting foot
- ⑨ Quilting foot
- ⑩ Hemmer foot
- ⑪ Cording foot
- ⑫ Open toe foot
- ⑬ Non-stick foot
- ⑭ Invisible zipper foot
- ⑮ Darning/embroidery foot
- ⑯ Electronic buttonhole foot
- ⑰ Thread net
- ⑱ Needle set (#75/11*2, #90/14*3)
- ⑲ Twin needle (#80/12, 2.5mm)
- ⑳ Bobbin (3x)
- ㉑ Edge/quilting guide
- ㉒ Stylus
- ㉓ Second spool pin
- ㉔ Spool pin felt
- ㉕ Spool holder (S)
- ㉖ Spool holder (M)
- ㉗ Spool holder (L)
- ㉘ Straight stitch needle plate
- ㉙ Extension table
- ㉚ Knee lifter
- ㉛ Seam ripper/brush
- ㉜ Screwdriver
- ㉝ L-screwdriver

Using the accessory box



Hold the sewing table horizontally, then pull toward the left to remove it from the machine.

Attach the sewing table, and then push it to the right.

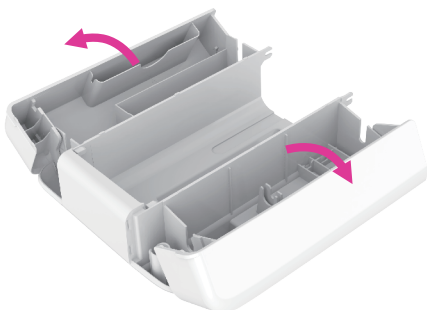

The inside space of the sewing table is used as an accessory box.

To store the accessories in the compartment of the sewing table, pull the top of the flat bed attachment to open the accessory compartment.

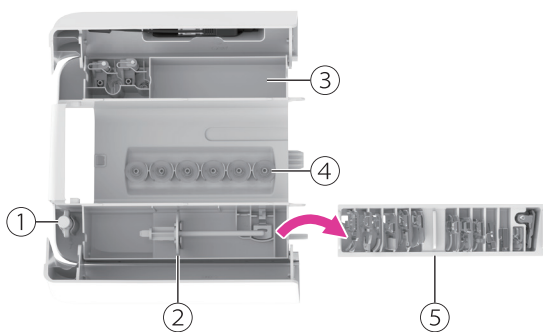

Individual compartment for specific purpose storage.

- ① Screwdriver storage space
- ② Second spool pin storage space
- ③ Additional storage space
- ④ Bobbin storage space
- ⑤ Presser foot storage trays

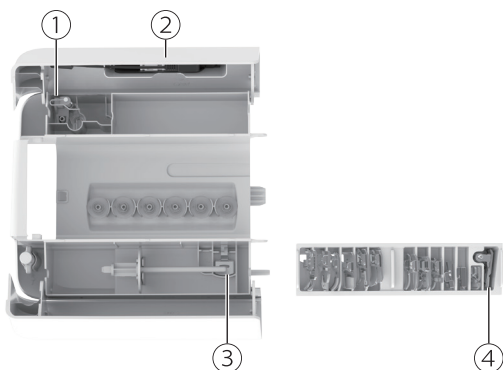

Specific presser foot can be stored in designated space.

- ① Darning/embroidery foot (RX)
- ② Electronic buttonhole foot
- ③ Gathering foot (JD)
- ④ Blind hem foot (DM)

Other accessories can be also stored in the compartment in the presser foot storage trays.

Connecting machine to power source



⚠ Attention

Always make sure that the machine is unplugged from power source and the main switch is off ("O"), when the machine is not in use and before inserting or removing parts.

Before connecting the power supply, make sure that the voltage shown on the rating plate is conforming with your main power.

Put the machine on a stable table.

1. Connect the machine to a power source as illustrated.
2. Turn the power switch to on ("I").

The sewing lamp will light up when the switch is turned on.

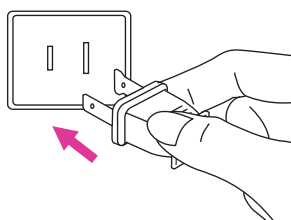

Polarized plug information

This appliance has a polarized plug (one blade is wider than the other), to reduce the risk of electrical shock; this plug will fit in a polarized outlet only one way. If the plug does not fit fully in the outlet, reverse the plug. If it still does not fit, contact a qualified electrician to install the proper outlet. Do not modify the plug in any way.

Foot control

When the machine is off, insert the foot control plug into its connector on the machine.

Turn on the machine, and then slowly press down the foot control to start sewing. Release the foot control to stop the machine.

Sink the heel back on the foot control to raise/lower the needle. The foot control can be programmed individually.

Note

Consult a qualified electrician if in doubt as to connect the machine to the power source.

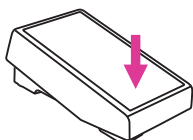
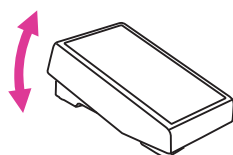



Machine Setup

Sewing table



Hold the sewing table horizontally, then pull toward the left to remove it from the machine.

Attach the sewing table, and then push it to the right.

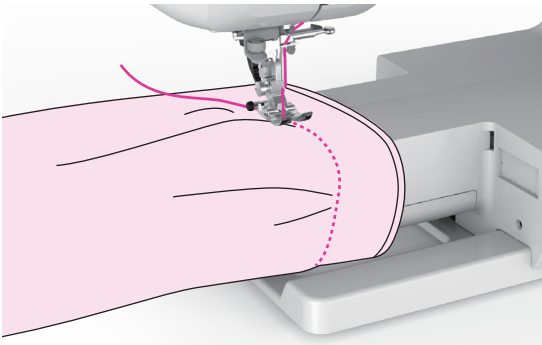

Free arm

Free-arm sewing is convenient for sewing tubular areas such as pant hems and cuffs

Using the extension table



Pull the sewing table and accessory box off by sliding it to the left.

Follow the arrow, and stretch the foot of the extension table.

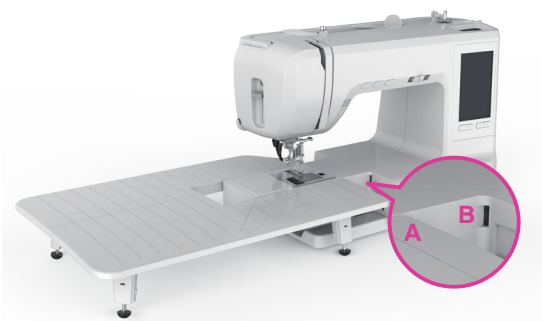

Snap (A) of the extension table into (B) of the machine.

Extension table can help moving during sewing.

Note

The needle must always be at the highest position.

Two-step presser foot lifter

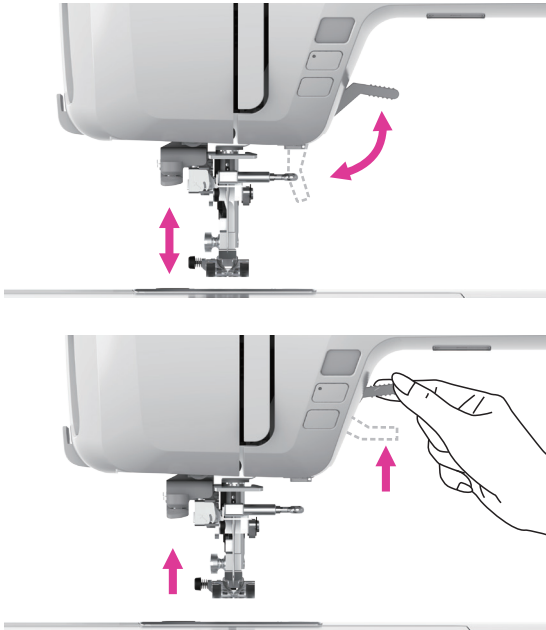

The presser foot lifter is to raise or lower your presser foot.

When sewing multi-layers or thick fabrics, the presser foot can be further raised up manually to allow enough space for your sewing work.

Note

The needle must always be at the highest position.

Using the knee lifter

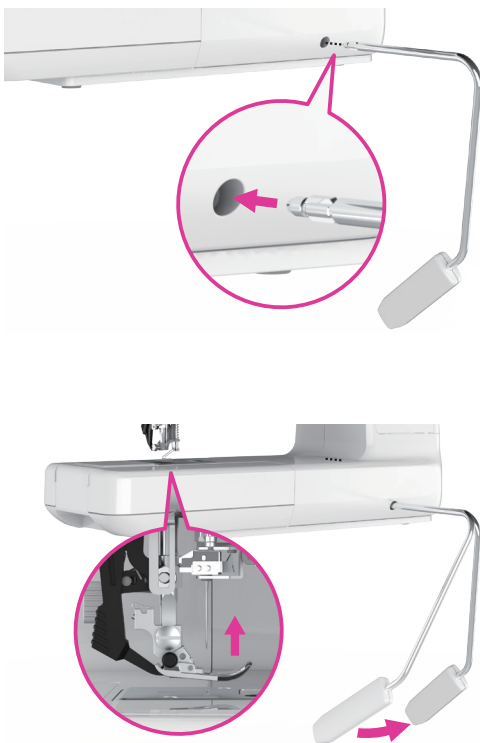

The knee lifter is extremely helpful when sewing applique, patchwork and quilting since it allows you to handle the fabric while your knee controls the presser foot.

Match the ribs on the knee lifter with the notches in the knee lifter socket and insert the knee lifter.

Adjust the sitting height so that the knee lifter can be operated with the knee.

Push the knee lifter with the knee to the right to raise the presser foot. Simultaneously the thread tension is released.

Release the knee lifter slowly to lower the presser foot.

⚠ Attention

Do not touch the knee lifter while sewing, otherwise the fabric will not be fed correctly.

Dual feed system (DFS)

The DFS system feeds fabric from the top and bottom simultaneously to ensure matching of checked, striped or plaid fabrics. When sewing light or difficult materials such as silk or rayon fabrics, the DFS system prevents seam puckering.

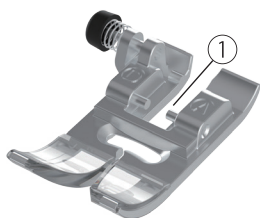

⚠ Attention

For all work with the DFS, use presser feet with the center back cut-out.

① Center back cut-out

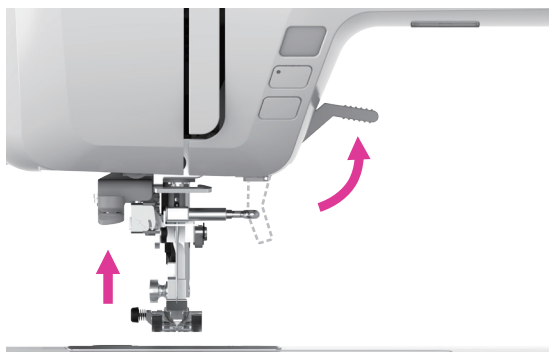

To engage the DFS

Raise the presser foot lifter.



Lower the DFS mechanism slowly.



Swing the DFS mechanism forward under the back of the presser foot until it is engaged and stays in the lowered position.

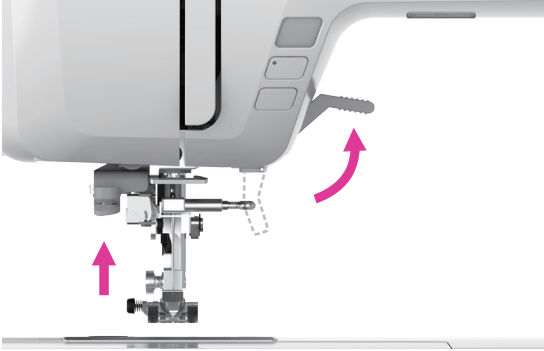

To disengage the DFS

Raise the presser foot lifter.



Pull down the DFS mechanism and swing it to the rear to disengage.

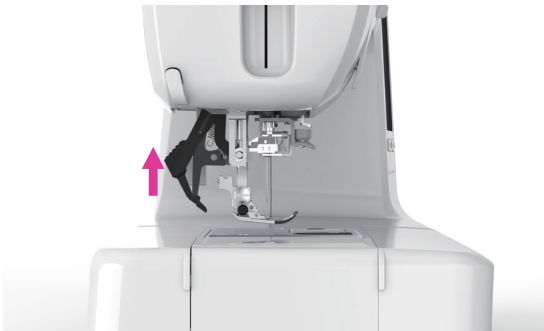

Push the DFS mechanism up.

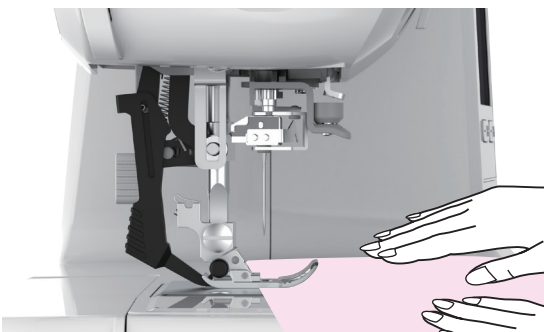

Fabric positioning

Place fabric flat on top of needle plate and position the fabric under presser foot.

While holding the thread tails with left hand turn handwheel with right hand to insert the needle into the fabric. Lower the presser foot and make 3-4 stitches.

Place hands on each side of the presser foot and gently guide the fabric while sewing.

Using the thread net

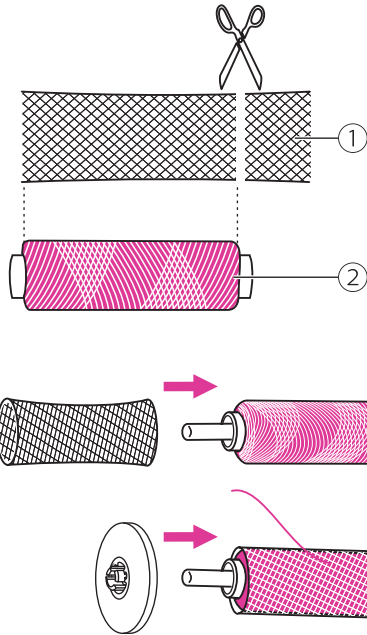

Note

- In order to prevent tangling of the thread, please use a thread net. The net is especially useful when using large or loose wound spools.
- Reduce the thread tension if necessary.

When using special threads which spin quickly off the thread spool, attach a net to the spool before using.

If the net is too long, cut the thread net to match the size of the spool.

- ① Thread net
- ② Thread

Winding the bobbin

It is important to carry out the threading correctly to get a quality sewing. Otherwise several problems will occur.

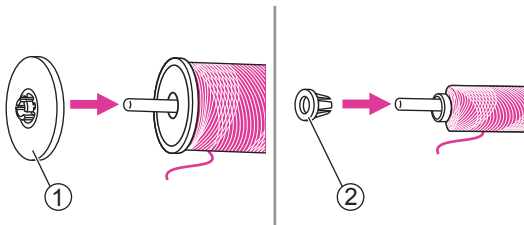
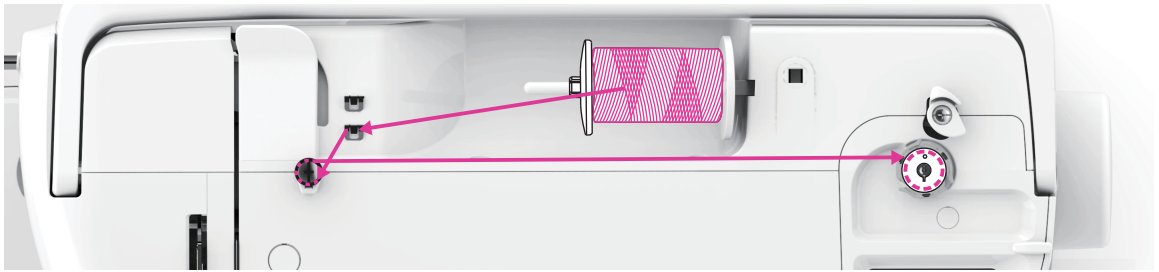

1. Place the thread and spool holder onto the spool pin. For better sewing quality, choose a proper size of the spool holder for the thread and attach it next to the spool.

- ① Large spool holder
- ② Small spool holder

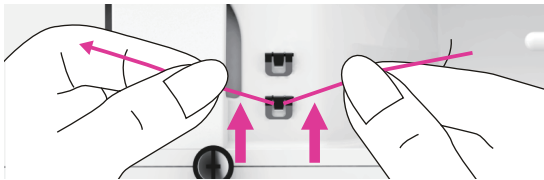

2. Draw the thread from the spool and place the thread in between the bobbin thread guide.

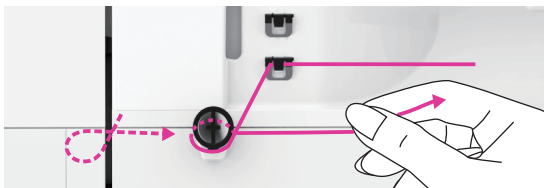

3. Wind the thread clockwise around the tension discs.

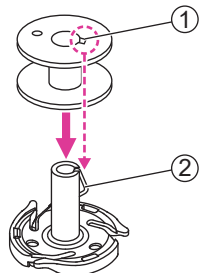

4. Place the empty bobbin on the bobbin winder spindle. Then align the notch with bobbin winder spindle spring.

- ① Notch
- ② Bobbin winder spindle spring

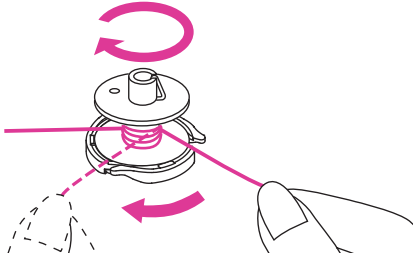

5. Wind the thread clockwise around the bobbin 5-6 rounds.

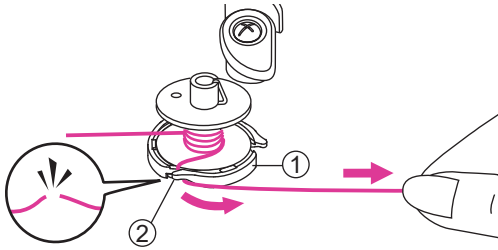

6. Wind the thread into the cutter of bobbin winder base and pull the thread to the right to cut.
 - ① Bobbin winder seat
 - ② Guide slit (with built-in cutter)

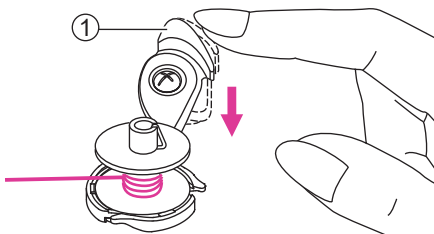

7. Push the bobbin winder switch, when the bobbin winder spindle is in position, it will start winding the bobbin. When winding is finished, the bobbin winder switch will stop and automatically pop back to original position.
 - ① Bobbin winder switch

△ Attention

Since this machine is equipped with an independent bobbin winder, the sewing speed controller does not effect the winding speed. Keep fingers clear of the needle area while winding the bobbin.

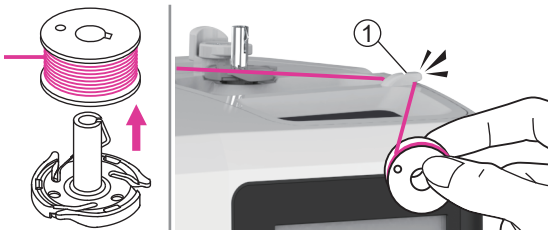

8. Remove the bobbin then use the thread cutter on the right side to cut.
 - ① Thread cutter

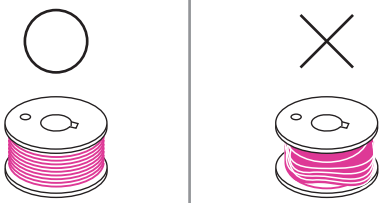

Note

Use a bobbin that has been correctly wound with thread, otherwise the needle may break or the thread tension will be incorrect.

Inserting the bobbin

⚠ Attention

Turn the power switch to off ("O").

When inserting or removing the bobbin, the needle and the presser foot must be fully raised.

Open the bobbin cover by pushing the release button to the right.

① Release button

Insert the bobbin in the bobbin case with the thread running in a counter-clockwise direction (arrow).

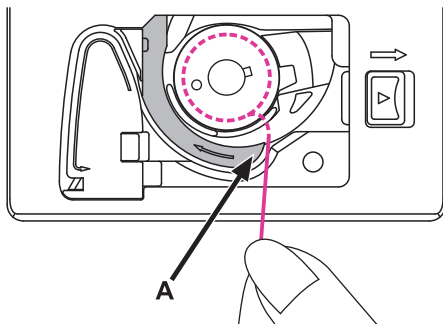
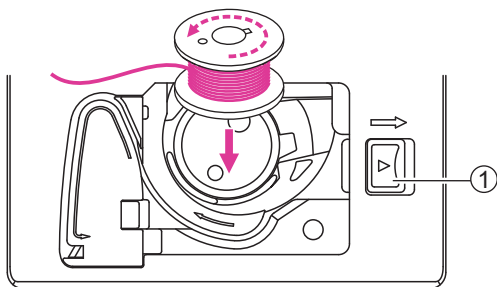

Pull the thread through the slit (A).

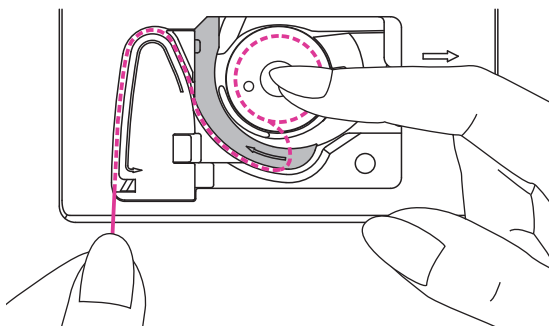

With a finger hold gently on top of the bobbin, please follow the arrow markings and draw the thread into the bobbin thread guide.

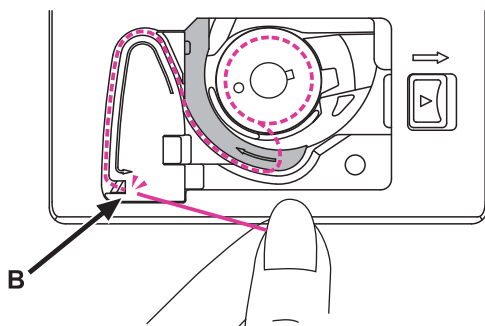

To cut off excessive thread, pull it to the cutter at point (B).

Close the bobbin cover.

Threading the upper thread

It is important to carry out the threading correctly to get a quality sewing. Otherwise several problems will occur.

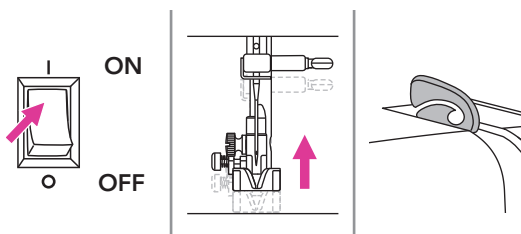
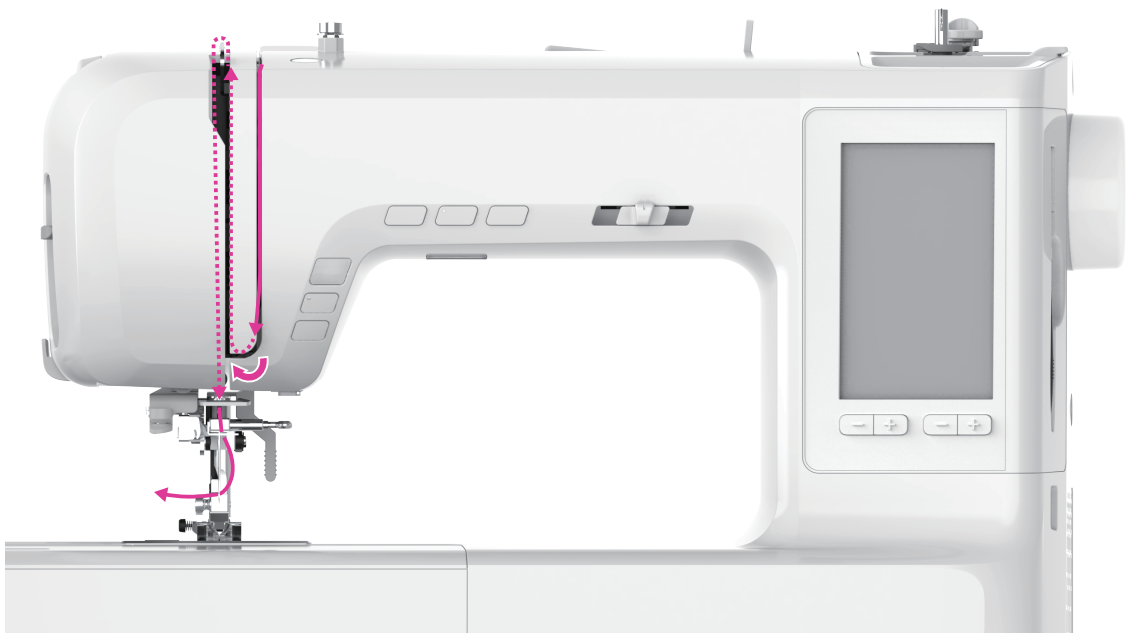
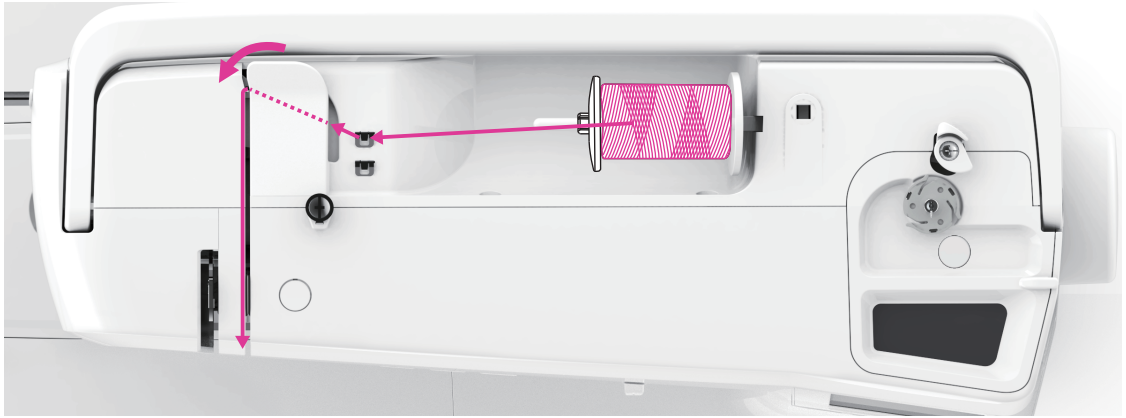

⚠ Attention

The needle threader can be with a 75/11 through 100/16 home sewing machine needle.

1. Turn the power switch to on ("I"), the needle, presser foot and take-up lever will automatically raise to the highest position.

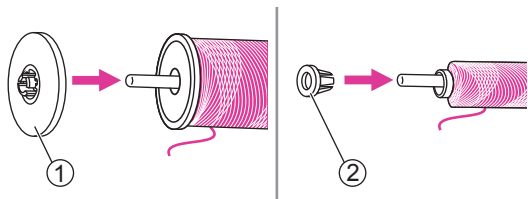

2. Place the thread and spool holder onto the spool pin. For better sewing quality, choose a proper size of the spool holder for the thread and attach it next to the thread.

- ① Large spool holder
- ② Small spool holder

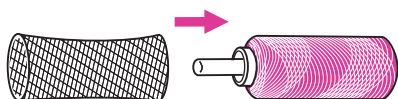

In order to prevent tangling of the thread, please use a spool net. The net is especially useful to work from large or loose wound spools.

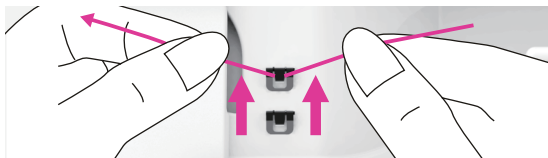

3. Draw the thread from the spool and place the thread in between the upper thread guide.

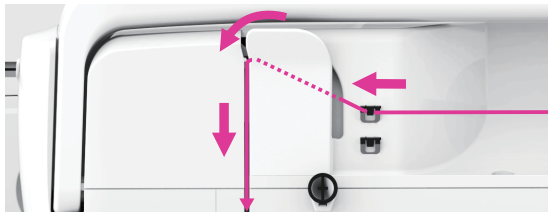

4. Guide the thread ahead and pull the thread through the pre-tension spring as illustrated.

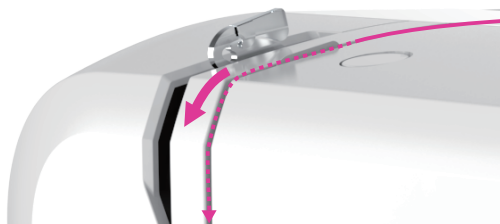

5. Continue to guide the thread into the silver discs to keep the thread in proper tension.

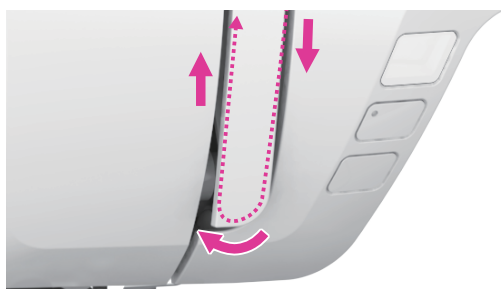

6. Pass the thread under the take-up spring then pull it upwards as arrow marks illustrated.

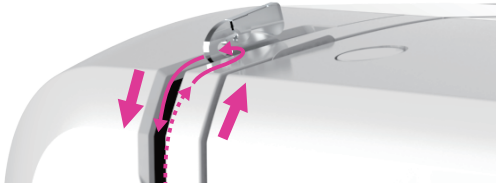

- Pull the thread to the top then pass the thread through the slotted eye of the take-up lever. Guide the thread down afterwards.

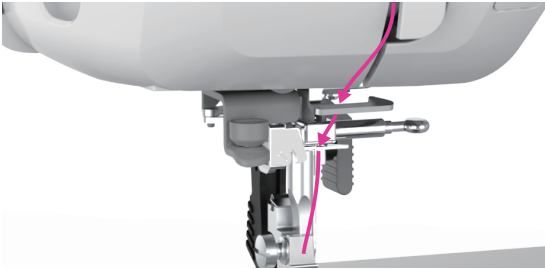

- Pass the thread behind the flat, horizontal thread guide. Threading to the right side of the thread guide.

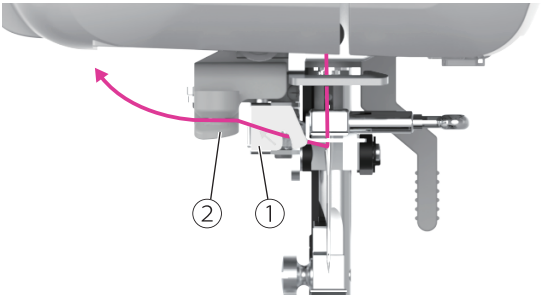

- Pull the thread to the left, pass through the guide plate from back to the front and then through the thread guide disk.
 - Guide plate
 - Thread guide disk

Note

Please make sure the thread is actually pass through the guide plate and thread guide disk, or it might cause thread cannot threading the needle eye successfully.

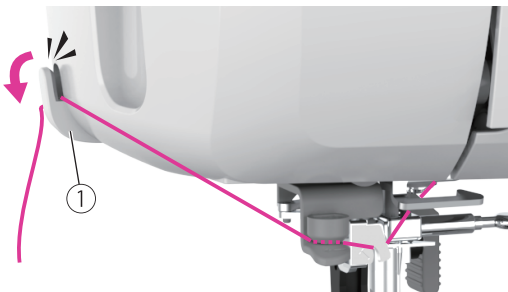

- Guide the threads to the side of the face plate and into the thread cutter to cut them.
 - Thread cutter

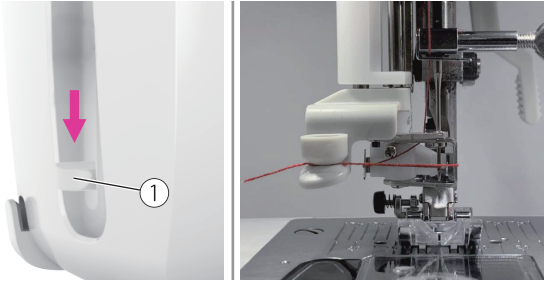

11. Press down the automatic needle threader lever on the left side of face cover to the bottom, when you hear a "click" sound, it is the correct position and the hook pin passes through the needle eye.

① Lever

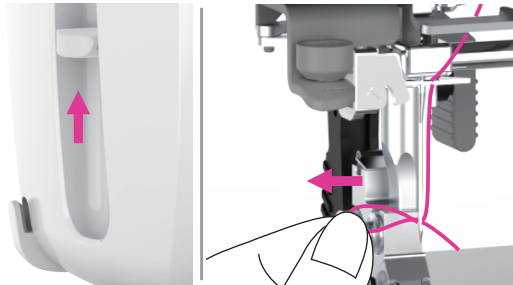

12. Raise the lever, the hook will rotate and pass the thread through the needle eye to form a loop.

Pull the thread through the needle eye to finish threading.

Note

Your machine is threaded and ready for sewing, follow the instructions on "Starting to sew" chapter to start sewing.

Bringing up the bobbin thread

When sewing gathering or smocking stitch, bring up the bobbin thread first as below instruction.

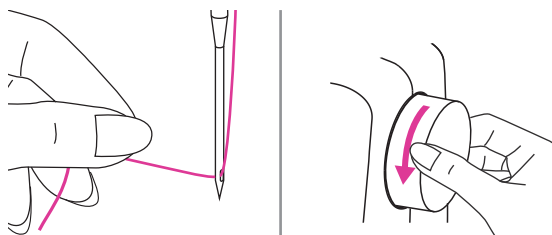

Hold the upper thread with your left hand. Turn the handwheel towards you (counter-clockwise) to lower the needle down below the needle plate then raise it to bring the bobbin thread up.

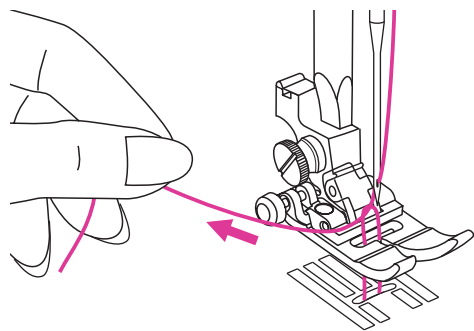

Gently pull on the upper thread to bring the bobbin thread up through the needle plate hole. The bobbin thread will come up in a loop.

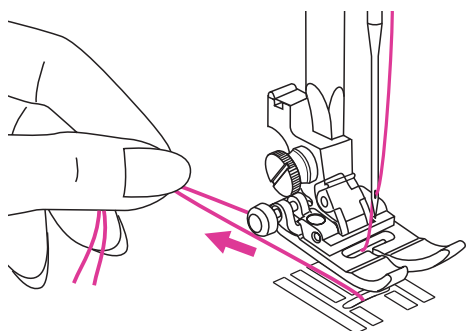

Pull both threads to the back under the presser foot.

Replacing the needle

Change the needle regularly, especially when it shows signs of wear or if it causes problems.

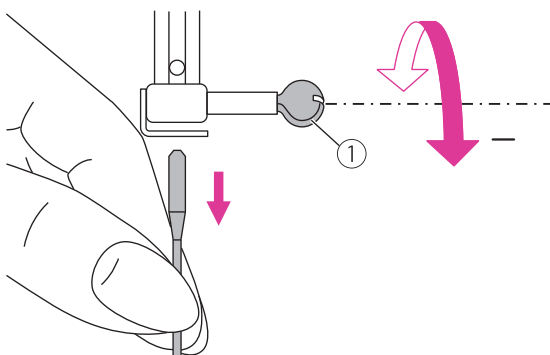

⚠ Attention

Turn the power switch to off ("O") when carrying out below operations!

Turn the handwheel toward you to raise the needle then loosen the needle clamp screw to remove the needle.

- ① Needle clamp screw

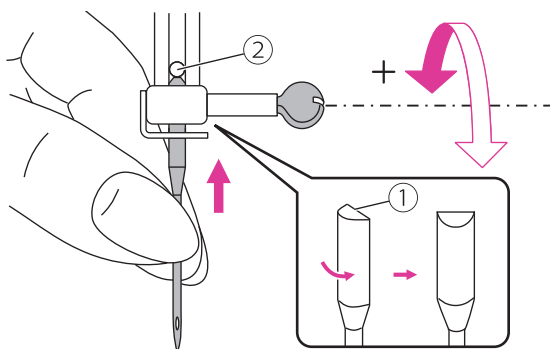

When inserting a new needle, keep the flat side of the shaft to the back.

Push the needle into the clamp until it touches the pin and stops. Then secure it by tightening the needle clamp screw.

- ① Flat side of the shaft
- ② Pin

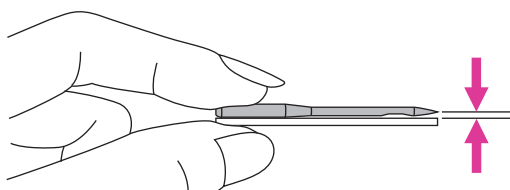



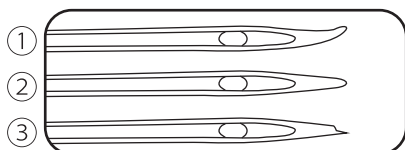

Needles must be in perfect condition.



Problems can occur with:

- ① Bent needles
- ② Blunt needles
- ③ Damaged points

Matching needle/fabric/thread

| FABRICS | THREAD | NEEDLE SIZE |
|--|---|---|
| Lightweight fabrics- thin cottons, voile, serge, silk, muslin, Qiana, interlocks, cotton knits, tricot, jerseys, crepes, woven polyester, shirt & blouse fabrics. | Light-duty thread in cotton, nylon, polyester or cotton wrapped polyester. | 65/9 - 75/11  |
| Medium weight fabrics- cotton, satin, kettleclote, sailcloth, double knits, lightweight woolens. | Most threads sold are medium size and suitable for these fabrics and needle sizes. | 80/12  |
| Medium weight fabrics- cotton duck, woolen, heavier knits, terrycloth, denims. | Use polyester threads on synthetic materials and cotton on natural woven fabrics for best results. Always use the same thread on top and bottom. | 90/14  |
| Heavyweight fabrics- canvas, woolens, outdoor tent and quilted fabrics, denims, upholstery material (light to medium). | | 100/16  |

Note

- In general, fine threads and needles are used for sewing fine fabrics, thicker threads and needles are used for sewing heavy fabrics.
- Always test thread and needle size on a small piece of fabric which will be used for actual sewing.
- Use the same thread for needle and bobbin.
- Use a stabilizer or place a backing for fine or stretchy fabrics, and select the correct presser foot.
- It is recommended that a 90/14 needle should be used when embroidering on heavyweight fabrics or stabilizing products (for example, denim, puffy foam, etc.). A 75/11 needle may bend or break, which could result in injury.
- For transparent nylon thread, always use needle 90/14 - 100/16. The same thread is usually used for the bobbin thread and upper threading.

Changing the presser foot

⚠ Attention

- Turn the power switch to off ("O").
- Always use the proper foot for the selected stitch. The wrong foot can cause the needle to break.

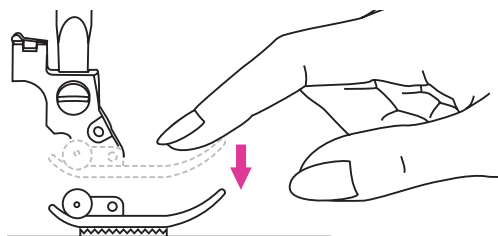

Remove the presser foot

Raise the presser foot lifter.

Press down on the front of the presser foot sole by hand.

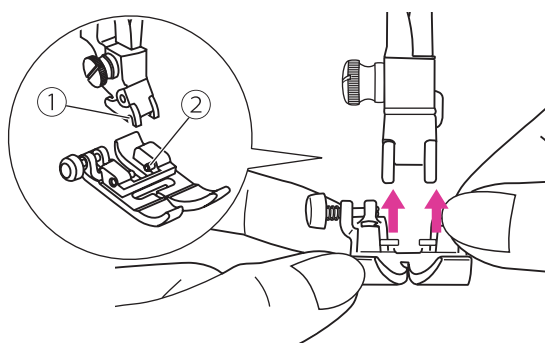

Attach the presser foot

Raise the presser foot lifter.

Place the presser foot under the shaft groove so that the shaft groove is above the presser foot sole pin.

Then push the new presser foot sole upward until it engages.

- ① Shaft groove
- ② Pin

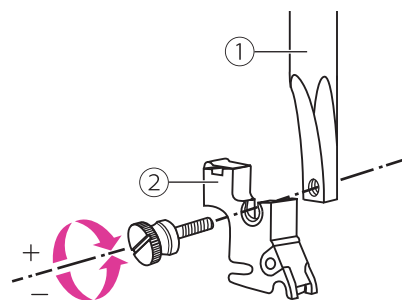

Remove and insert the presser foot holder

Raise the presser foot lifter. Align the presser foot holder with the lower left side of the presser bar. Hold the presser foot holder, then tighten the screw using the enclosed screwdriver.

- ① Presser foot bar
- ② Presser foot holder

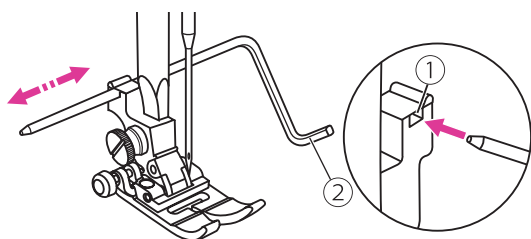

Insert the edge/quilting guide

Insert the edge/quilting guide in the slot as illustrated. Adjust the needed width according to your sewing applications.

- ① Slot
- ② Edge/quilting guide

Replacing the needle plate

⚠ Attention

Turn the power switch to off ("O").

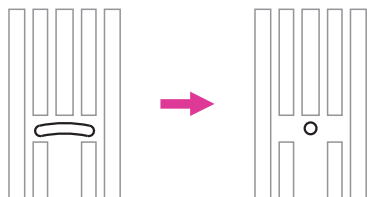

The straight stitch plate is recommended for embroidery mode for better embroidery quality. It can be also used for straight stitches in middle needle position in normal sewing mode.

The particular design of smaller central hole can give a better support of the fabric during straight stitch sewing.

Thus, the fabric can be prevented from being pulled down into bobbin/hook area, especially in the beginning or end of a seam.

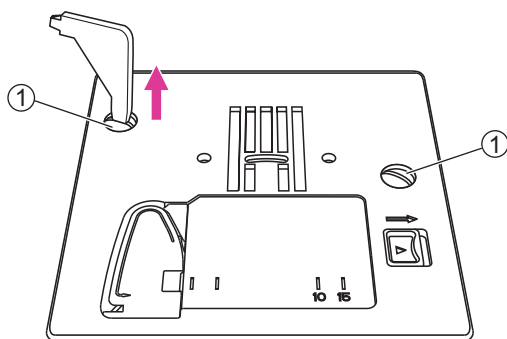

Remove the needle, presser foot and presser foot holder.

Remove the screws on the needle plate then remove the needle plate.

① Screws

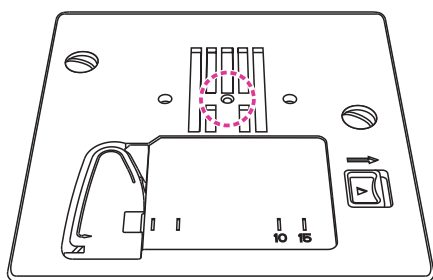

Change the straight stitch plate and tighten the screws.

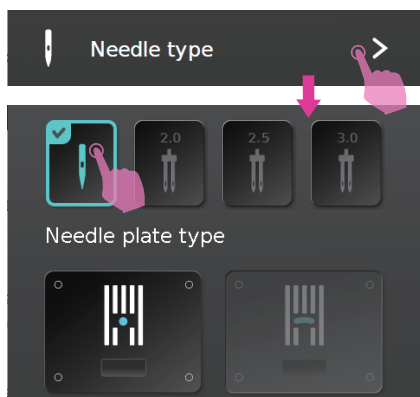

After changing to straight stitch plate, please go to needle type setting and choose single needle, the machine will automatically sensor which needle plate is using.

The stitch width is automatically selected.

To raise or drop the feed dogs

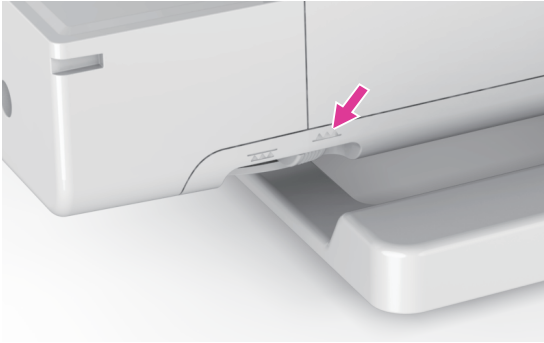

The drop feed lever can be seen on the base at the front side of the sewing machine, when the sewing table is opened.

Sliding the drop feed lever to lower or raise the feed dogs. When lever is in raised position, the feed dog will arise automatically when you are sewing.

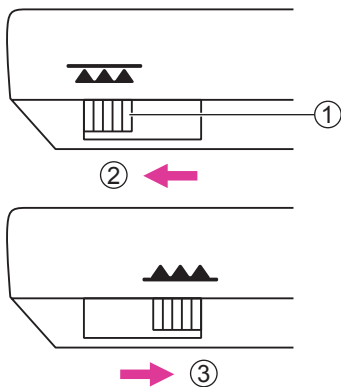

- ① Drop feed lever
- ② Lowered position
- ③ Raised position

Note

When you finish the work, (e.g. button sewing, free motion darning, embroidery and monogramming), please move the drop feed lever to raised position for general sewing purpose.

Operation buttons

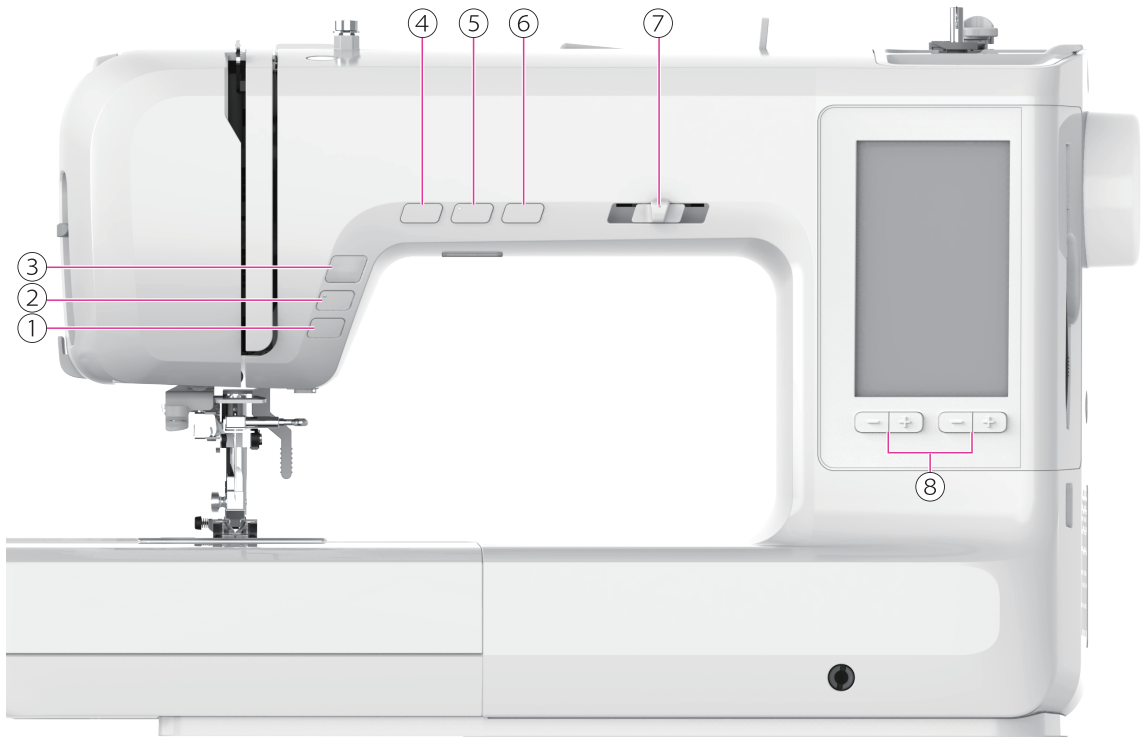

① Reverse button

The machine will sew reverse at a low speed if the reverse button is pressed.

The machine will sew forward after the button is released.

Note

The utility stitches number 013, 033-038 and the button holes stitches number 039-054 can not use reverse button function. If reverse button is pressed, the machine will stop and make a hint sound.



② Auto-lock button

When machine is not sewing: Press the auto lock button, machine will sew locking stitches in the same position then stop. The LED light on the button will flash during auto-lock sewing and stop when it's finished.

During machine is sewing: Press the auto lock button, the machine will execute auto-lock according to pattern unit setting. The LED light on the button will flash during auto-lock sewing and stop when it's finished.

Note

- While combination pattern is sewing and pressing auto-lock button, it will execute auto-lock after the current pattern is completed.
- To set up number of stitches on auto-lock, please refer to the chapter "Settings".
- Auto-lock setting on pattern unit, please refer to "Setting stitch" chapter for more information.



③ Start/stop button

Press the start/stop button to start machine running. Press the start/stop button again to stop machine.

The LED light colors on the button will change according to its operation mode:

- Green light: the machine is ready or is running
- Orange light: Not in conditions to sew
- Red light: Machine can not sew

This way you may operate the machine without foot control.

Note

When the presser foot is up, press and hold the start/stop button, the machine will automatically lower the presser foot and start sewing.



④ **Presser foot up/down position button**

Press presser foot up/down button, presser foot will go up and press again to lower the presser foot.

Note

During sewing, can not use presser foot up/down button.



⑤ **Needle up/down position button**

With the needle up/down position button, you decide whether the needle stops in the highest or in the lowest position (i.e. in the fabric) when you stop sewing. If the needle is set to be down, then the LED light will turn on.

Press needle up/down button, the needle will go up and pressing again will go down.

Note

During sewing, can not use the needle up/down button.



⑥ **Thread cutter button**

Press this button after finishing sewing and the machine will trim the thread.

After executing cutting the thread, press start/stop button then will continue to sew.

Note

- During sewing, can not use the thread cutter button.
- To set up auto-lock function, please refer to chapter "Setting".



⑦ Speed adjustment slider

In the sewing mode, the speed adjustment slider can control the sewing speed. To increase the speed, slide the lever to the right. To decrease the sewing speed, slide the lever to the left.

The sewing speed can be adjusted without foot controller.



⑧ Value setting buttons (Left/Right)

Press "-" button to decrease the value; press "+" button to increase the value. This button can be used to adjust the value in each screen.



| Instruction

LCD screen



- ① Pop out and close the menu selection
- ② Home
- ③ Settings
- ④ Tutorials
- ⑤ Advisor
- ⑥ Safety

Note

Use only your finger or the included stylus to tap the screen. Please do not use a sharp pencil, screwdriver, or other stiff, sharp objects. Do not click the screen forcefully. If click hard or use a sharp objects may damage the screen.

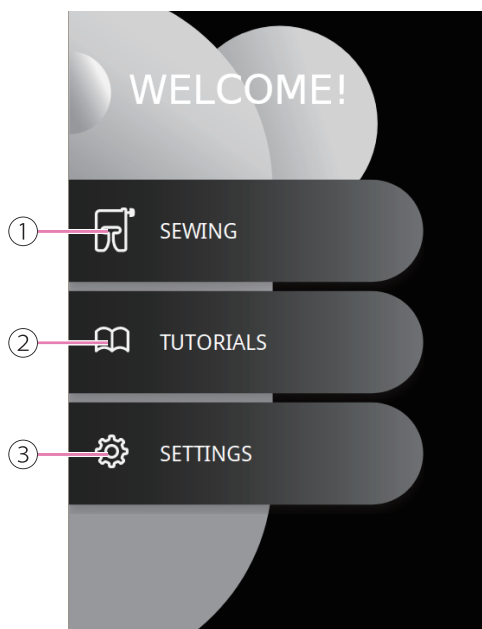

Home page

- ① Sewing
- ② Tutorials
- ③ Settings



①



②



③



④

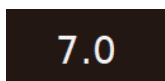

⑤

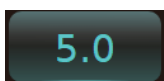













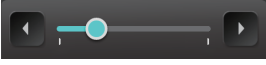

⑥

Note

- ① Function not available
- ② Function available
- ③ Function is already enabled or active
- ④ Value is not adjustable
- ⑤ Default value
- ⑥ Value is already adjusted, click on the value to go back its default value.

Function buttons and icon

| Icon | Name | Application |
|--|----------------------------|---|
|  | Switch pages | Switch pages up/down |
|  | | |
|  | | |
|  | Turn on/off switch | ① Turn on function ② Turn off function |
|  | Back to default value | |
|  ①  ② | Slider | Hold the slider to increase or reduce setting values ① Default values ② Values are adjusted |
|  | Reduce/increase | Reduce or Increase setting values |
|  | Virtual multifunction icon | By function to adjust the position, spacing, curvature, degree of rotation, etc. |
|  | Virtual multifunction icon | By function to adjust the position |
|  | Select multiple points | Starting from the currently selected point, select forward/backward part. |
|  | Next step | To the next screen |
|  | Back | |
|  | Close | Sewing: Close window |

Settings

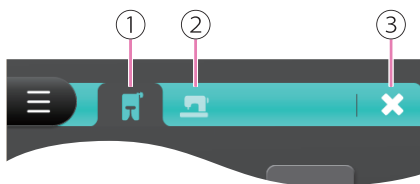

- ① Sewing setting
- ② Machine setting
- ③ Close setting page

Sewing setting

Change upper tension

Adjusting the upper thread tension will affect to all stitch patterns. Upper thread tension is also adjustable for current stitch pattern.

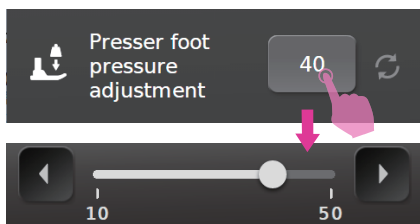
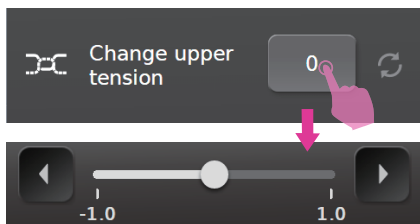

Presser foot pressure adjustment

The most suitable presser foot pressure can be adjusted according to the fabric thickness.

When sewing thick fabrics, it is recommended to reduce the pressure on the presser foot. So presser foot will slightly raise to make the fabric easier to be moved.

When sewing thin fabrics, it is recommended to increase the presser foot pressure. It will prevent the fabric from moving freely.



Muti-function foot controller

Initial setting by stepping on the back of the foot controller can lift /lower the needle.

The multi-function foot controller can be set up the auto-lock, trimming, or raising the presser foot function based on personal needs.

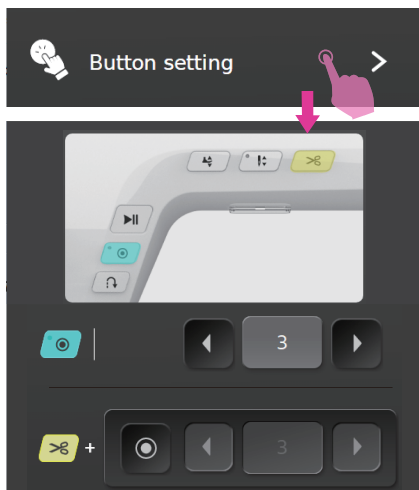

Button setting

Machine button setting, to set the number of stitches of auto-lock at the end of pattern sewing, whether to execute the auto-lock function before trimming and the number of stitches of auto-lock.

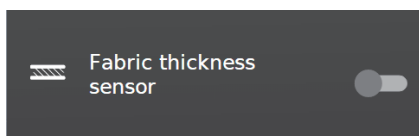

Fabric thickness sensor

When the sensor is turned on, machine will detect the fabric thickness and will adjust presser foot pressure to make sure the fabric moves forward stable.

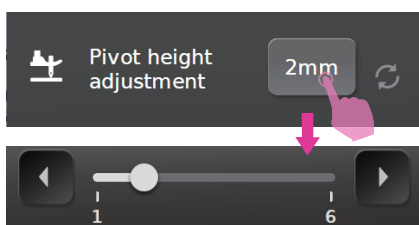

Pivot height adjustment

The pivot height can be changed according to the type of fabric. When sewing is stopped, the needle is at lower position and the presser foot is raised to the set height.

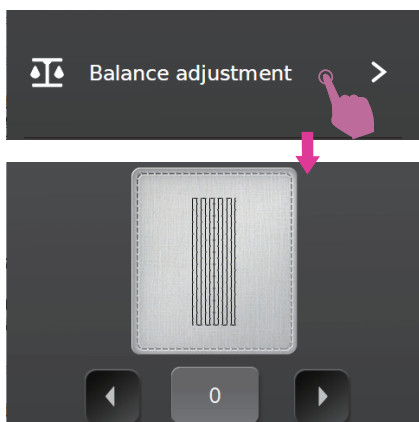

Balance adjustment

Different fabrics, threads and stabilizers will affect the sewing result. It may result in the inability to sew the correct pattern. Balance adjustment can correct such differences and the pattern can be made according to the most suitable adjustment for selected fabric.

Select a pattern to sew, and it will display on the preview screen. Comparing the sewing result with the desired patterns, click the "left" or "right" icon or slider to adjust the balance, until the pattern previewed on the screen and result on the fabric are the same. The machine will automatically to adjust the stitch balance accordingly.

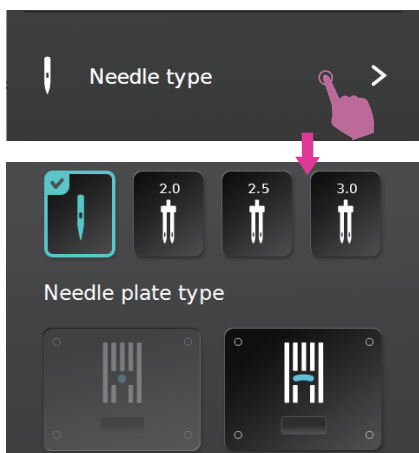

Needle type

After replacing the needle plate, machine will automatically detect whether it's using the correct needle plate. It also can select the needle type in this same page.

Note

Please use single needle for embroidering.

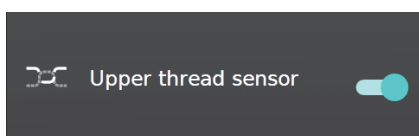

Machine setting

Upper thread sensor

Turn on/off upper thread sensor, when the upper thread is broken, not threaded correctly or thread is about to run out, a warning message will pop out on the screen.

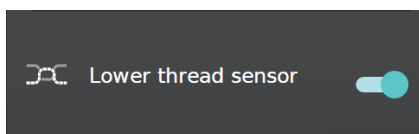

Lower thread sensor

Turn on/off lower thread sensor, when the lower thread is broken or thread is about to run out, a warning message will pop out on the screen.

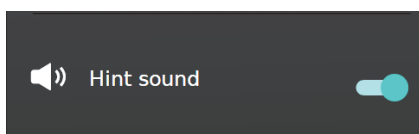

Hint sound

To turn on/off the sound. Default setting is on.

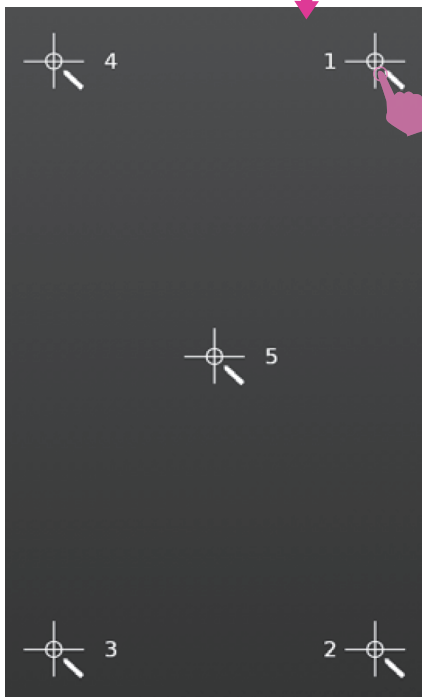
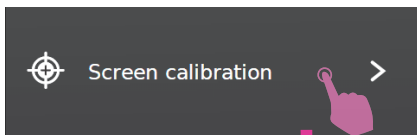
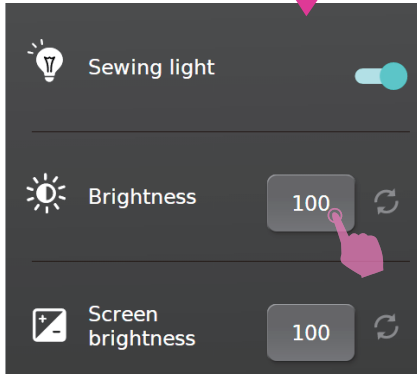
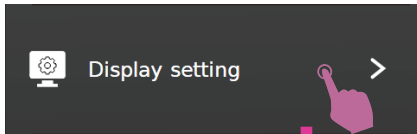

Display setting

To adjust the light brightness on the working area and display brightness.

Screen calibration

Follow and click the number shown on the screen, clicked all 5 points to finish screen calibration.

When turn on the machine, press and hold the "+" physical buttons on the right and left multi-function buttons at the same time to enter the screen calibration function.

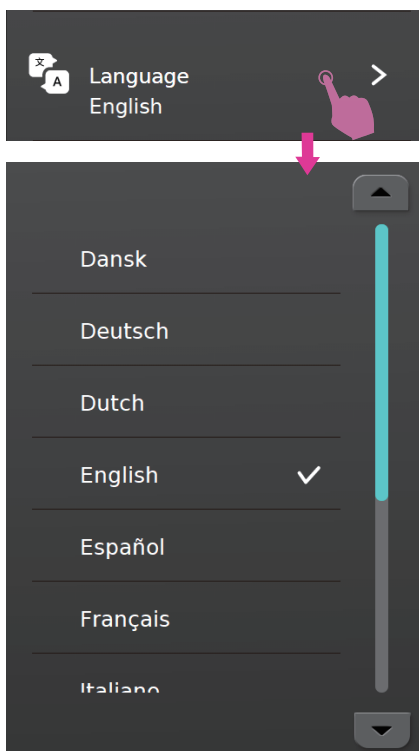

Language

To select different languages.

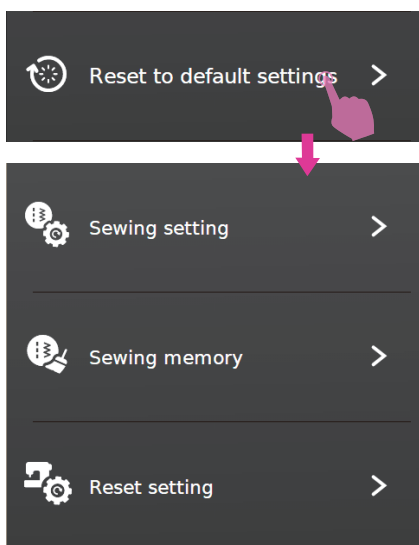

Reset to default settings

Restore factory settings. To remove all personal settings.

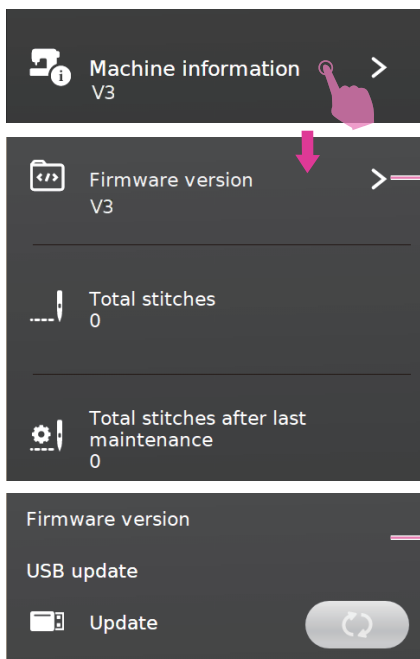

Machine information

Firmware version: Display current software version. A ! icon indicates any new version is detected.

Total stitches: Will display the total number of stitches have used after the machine left the factory.

Total stitches after last maintenance: Will display the cumulative number of stitches after last maintenance.

How to update your machine

Be sure to consult your local authorized dealer for updates for your machine.

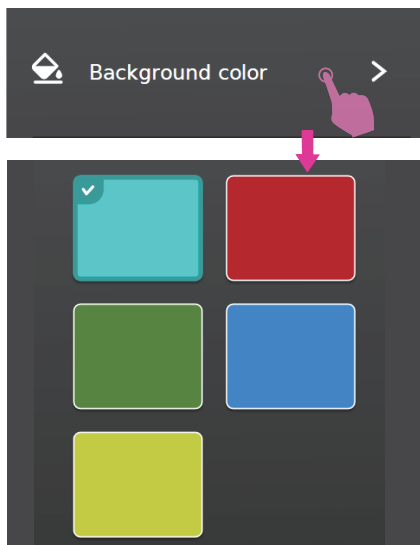

Background color

Select the background color.

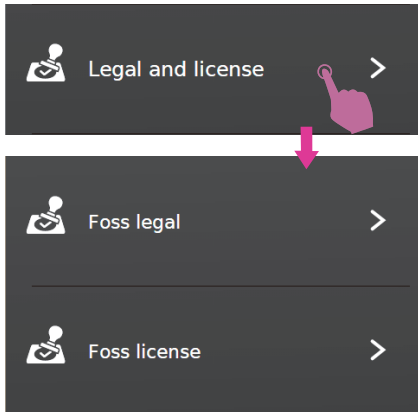

Legal and licence

Display related legal information.

Selecting stitch

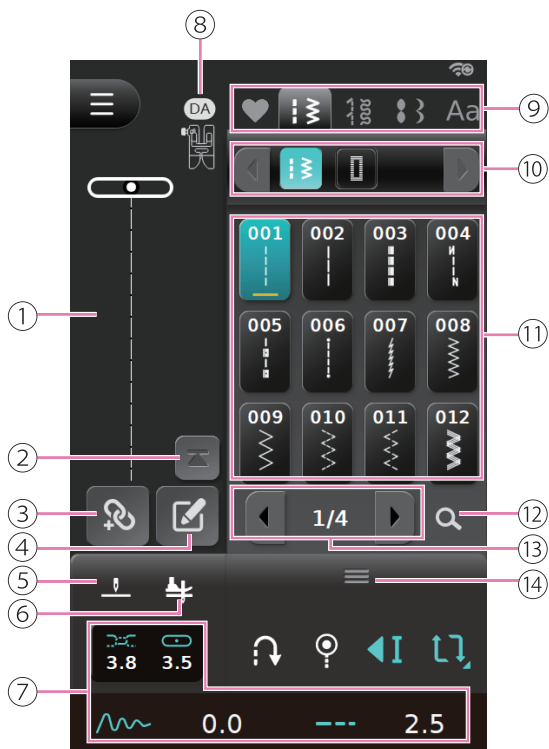

Introduction of sewing mode screen

- ① Needle position display
- ② Back to initial stitch
- ③ Combination mode
- ④ Edit mode
- ⑤ Needle up/down setting
- ⑥ Pivot setting
- ⑦ Sewing values adjustment(upper thread tension, needle position, length, width)
- ⑧ Suggested presser foot icon and reference number
- ⑨ Stitch pattern/letters category
- ⑩ Stitch pattern group
- ⑪ Stitch pattern list
- ⑫ Stitch pattern search
- ⑬ Switch pages
- ⑭ Toolbox

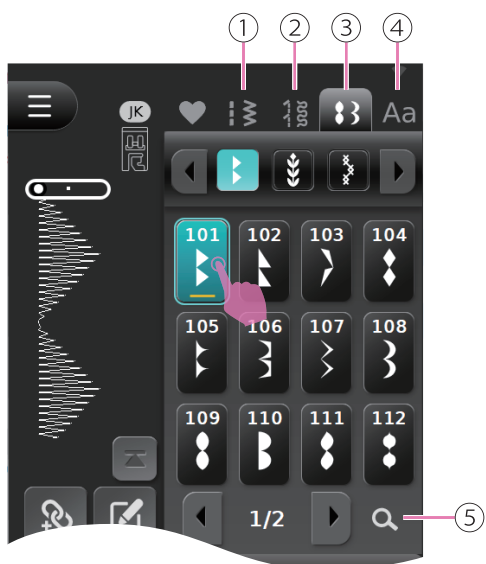

Selecting stitch

Turn on the machine and enter the sewing mode.

Select the desired stitch pattern by click the icon or search by using reference number.

- ① Utility stitches group
- ② Quilting stitches group
- ③ Decorative stitches group
- ④ Alphabet stitches group
- ⑤ Search for stitch pattern

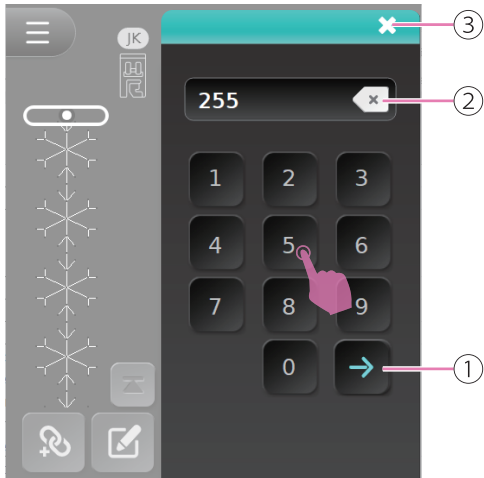

Click the Search icon and go to searching page, it can refer to the chart and key in the stitch pattern number. Click Confirm icon after key in the pattern number, close the page and it will appear the selected stitch pattern.

Click the Delete icon to delete last digit number, long press the Delete icon to delete all numbers.

- ① Confirm
- ② Delete
- ③ Close

After select the stitch pattern, the value is adjustable.



Note

- ① This stitch pattern can not be selected
- ② This Stitch pattern can be selected
- ③ This Stitch pattern can be selected, values have been adjusted
- ④ Stitch pattern that have been selected
- ⑤ Stitch pattern that have been selected, values have been adjusted

Altering stitch

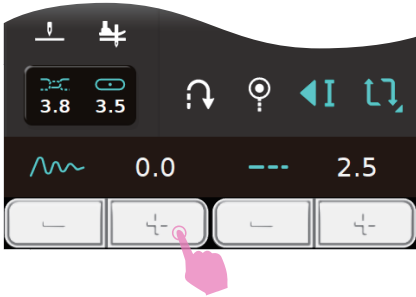

Altering the stitch width

When you select a stitch, the machine will automatically set the recommended stitch width values which will be shown on the LCD screen.

Press the "+" or "-" button to adjust the stitch width. For a narrower stitch, press the "-" button. For a wider stitch, press the "+" button.

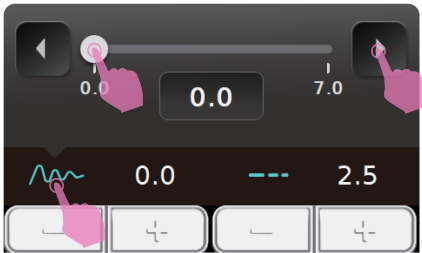

Click Width icon will pop out a slider window which can adjust the values faster. Click anywhere on the screen to leave the window. Click Width value icon can be returned to the default value.

Different stitches will have different width limitation.

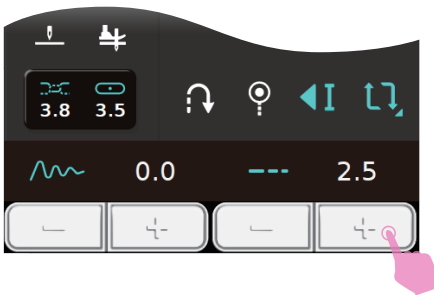

Altering the stitch length

When you select a stitch, the machine will automatically set the recommended stitch length values which will be shown on the LCD screen.

Press the "+" or "-" button to adjust the stitch length. For a shorter stitch length, press the "-" button. For a longer stitch length, press the "+" button.

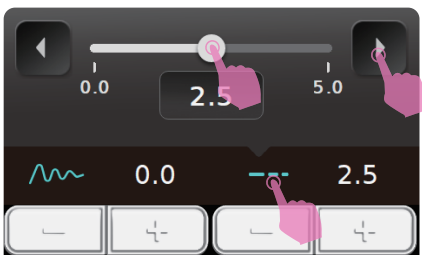

Click Length icon will pop out a slider window which can adjust the values faster. Click anywhere on the screen to leave the window. Click Length value icon can be returned to the default value.

Different stitches will have different length limitation.

Altering the thread tension

Proper tension setting is important for sewing. There is no single tension setting appropriate for all the stitch functions and fabrics.

After the stitch pattern is selected, the machine will automatically apply its default thread tension value.

Click Thread tension and Needle position icons, the stitch length/width setting will be replaced. Switch to the bottom of the screen and adjust the tension value.

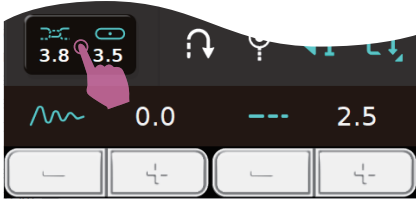

Press the "+" or "-" button to adjust the stitch tension.

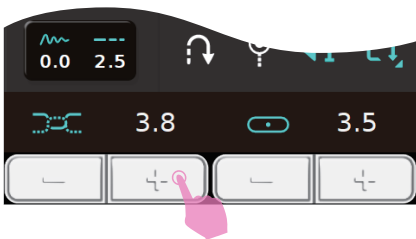

Click the Thread tension icon and a slider will pop out for quick value adjustment. Click anywhere on the screen to leave the window. Click the Thread tension value icon will reset the value to default.

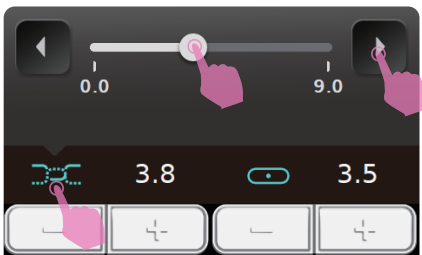

Normal thread tension for straight stitch sewing.

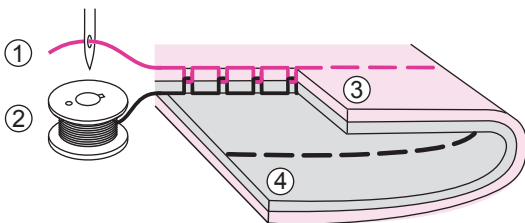

- ① Upper thread
- ② Bobbin thread
- ③ Surface
- ④ Wrong side

Thread tension is too loose for straight stitch sewing. To increase the tension, press the "+" button.

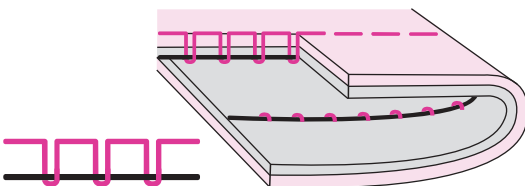

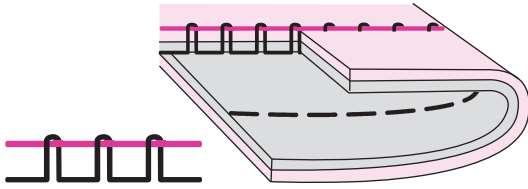

Thread tension is too tight for straight stitch sewing. To reduce the tension, press the "-" button.

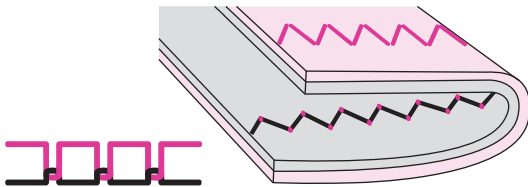

Normal thread tension for zig zag and decorative sewing.

For all decorative sewing you will always obtain a nicer stitch and less fabric puckering.

When a small number of the upper thread appears on the bottom side of fabric is the correct thread tension.

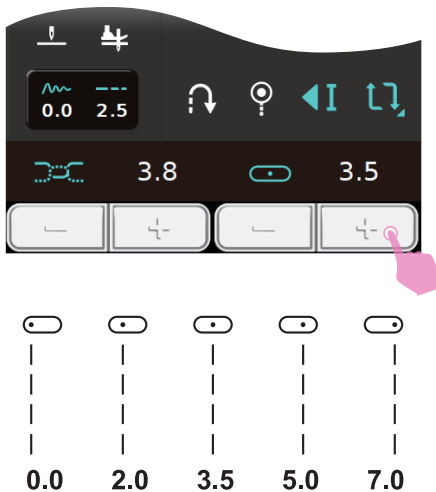

Changing needle position

Click Thread tension and Needle position icons, the stitch length/width setting will be replaced. Switch to the bottom of the screen and adjust the tension value.

The default position setting to "3.5", center position.

Press the "+" or "-" button to adjust the needle position. Press the "+" button to move the needle position to the right. Press the "-" button to move the needle position to the left.

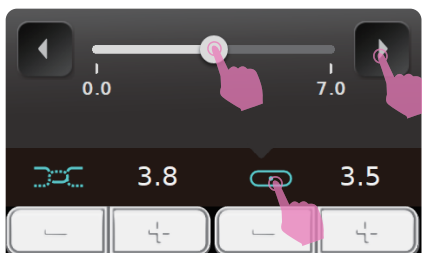

Click the Needle position icon and a slider will pop out for quick value adjustment. Click anywhere on the screen to leave the window. Click the Needle position value icon will reset the value to default.

Setting stitch

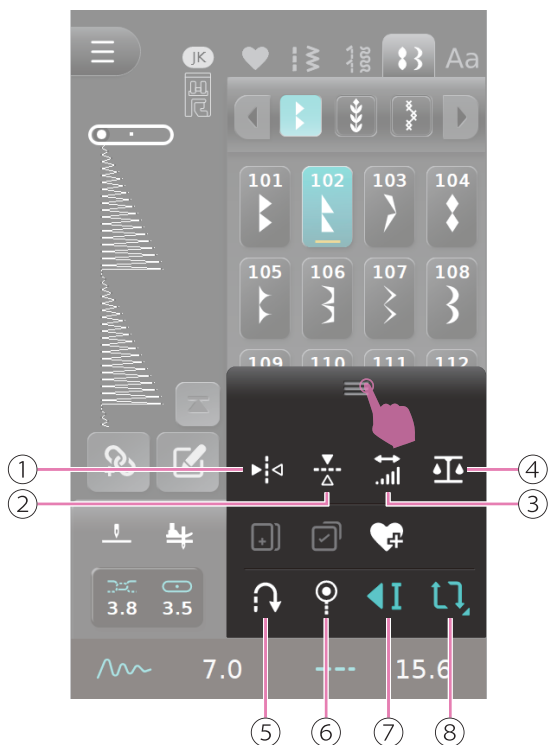

After selecting stitch pattern, open the tool box to adjust stitch pattern function setting.

- ① Horizontal mirror function
- ② Vertical mirror function
- ③ Elongation / Density setting
- ④ Balance calibration on current stitch pattern
- ⑤ Reverse sewing
- ⑥ Initial auto-lock
- ⑦ Pattern unit sewing
- ⑧ Stitch cycling setting

Note

If the pattern does not have this function, the icon will turn gray and can not be selected.

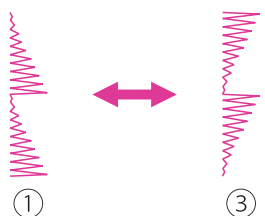
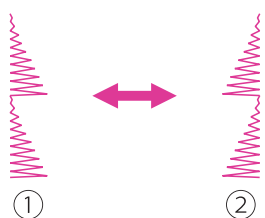

Mirror

The mirror function is to create the mirror image of selected stitch.

Click Horizontal mirror icon, the pattern can be flipped horizontally. Click Vertical mirror icon, the pattern can be flipped vertically.

The mirror stitch will display on the LCD screen.

The machine will continue to sew the mirror stitch until you click the icon again.

- ① Normal pattern
- ② Horizontal mirror function
- ③ Vertical mirror function



Elongation

Click the Left or Right icon or slider to adjust the stitch which can be elongated up to 5 times the original length.

For a longer stitch, click the Right icon. For a shorter stitch, click the Left icon.

The elongation stitch will display on the LCD screen.

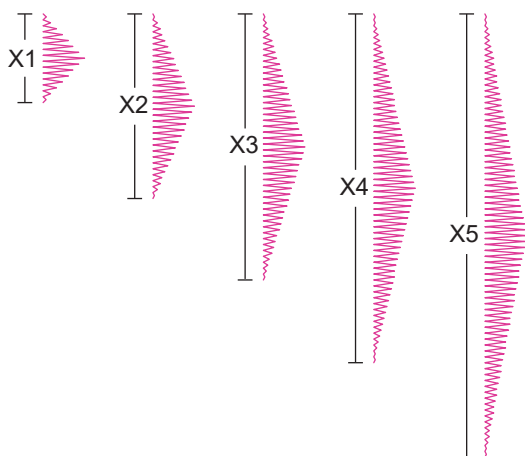

The machine will continue to sew the elongation stitch until you reset the elongation ratio.

When the width or length or stitch is changed, a greater variety of patterns are available.



Density

Click the Left or Right icon or slider to adjust the density. The density default setting is in high density.

Reduce density, click the Right icon.

Increase density, click the Left icon.

The density stitch will display on the LCD screen.

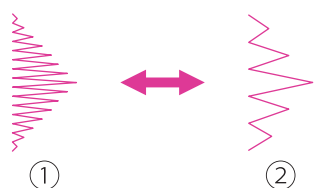

- ① Normal pattern
- ② Reduce density



Balance calibration on current stitch pattern

Different fabrics, threads and stabilizers will affect the sewing result. It may result in the inability to sew the correct pattern. Balance adjustment can correct such differences and the pattern can be made according to the most suitable adjustment for selected fabric.

Select a desired pattern or letter, it will display on the preview screen. Check the result after sewing.

Comparing the sewing result with the desired patterns, click the Left or Right icon or slider to adjust the balance, until the pattern previewed on the screen and result on the fabric are the same. The machine will automatically to adjust the stitch balance accordingly. The range can be adjusted from -50 to 50.

Note

Altered balance settings can be saved for each stitch in the my favorite program.



Reverse sewing

Click Reverse sewing icon for continuously reverse sewing. Stitch previewed on the screen will display reversely.

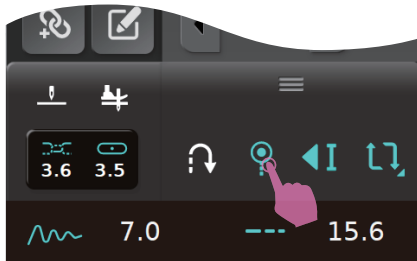

Initial auto-lock

Click Initial auto-lock icon, it will lock the stitches at the beginning of sewing. To set up the number of auto-lock stitches, please go to "Button Setting" in the Setting page.

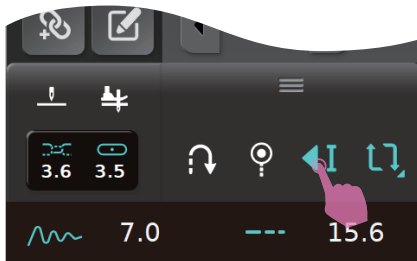

Pattern unit sewing

After click Pattern unit sewing icon, if you press the auto-lock button during the sewing, it will auto-lock the stitches after sewing a complete pattern unit.

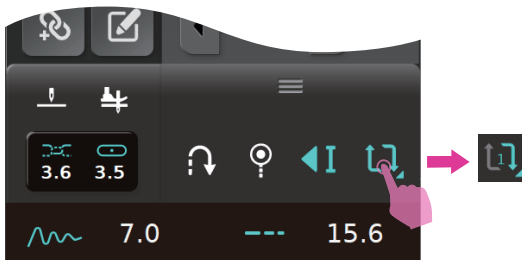

Stitch cycling setting

Click Stitch cycling icon one time to sew a complete pattern. Continuously click the Stitch cycling icon to set up the cycling times, it can up to 9 times. Long press the icon to reset the cycling times.

The icon will decrease with the number of sewing, after the sewing is completed, the machine will stop automatically.

My favorite program

You can set your favorite stitches and alphabets that you use most. Since stored patterns are not lost after the sewing machine is turned off, they can be recalled at any time.

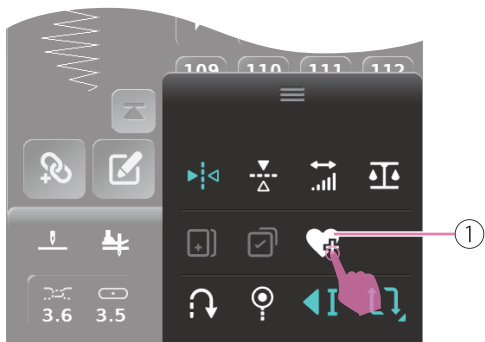

Save pattern

After editing the pattern, click My favorite icon to save the pattern.

- ① Add current stitch pattern to my favorite

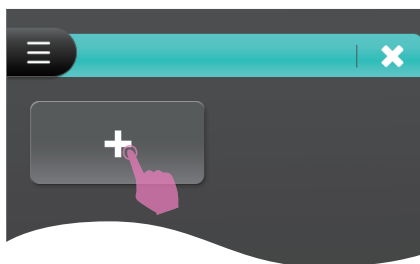

Click the "+" icon to save the pattern.

There are 100 patterns that can be saved in my favorite program, which creates a quick and easy access at all times.



Overwrite pattern

Click My favorite icon and select the pattern that want to be overwritten.

The warning message will pop out then click Confirm icon to overwrite the pattern.

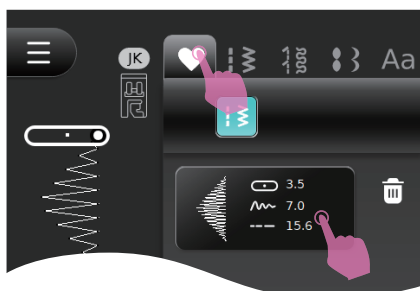

Recall pattern

Click My favorite icon to recall the saved patterns.

Press the start/stop button to start sewing.

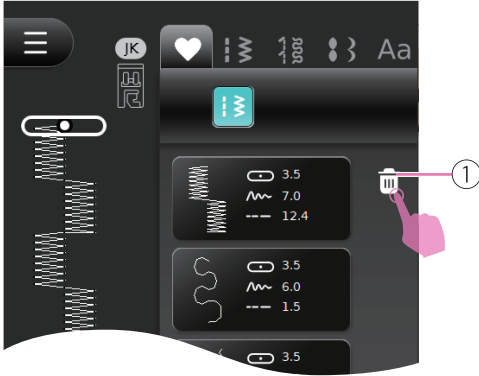

Delete pattern

To delete the saved patterns, click the Delete icon.

① Delete

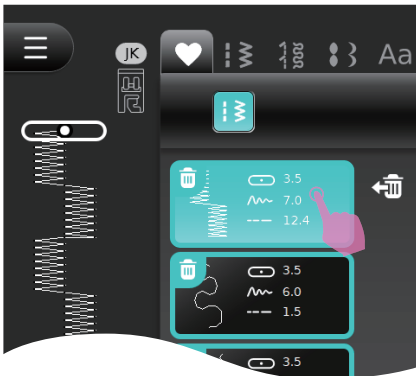

Select the pattern you want to delete.

The warning message will pop out, click Confirm icon to delete the pattern.

Click again the Delete icon, will exit delete mode.

Combination mode

To use the combine function, you can select each pattern to create combined patterns and continued sewing the combined patterns. This is convenient for patterns, such as names, that will be used often.



Combine patterns

Click Combination icon to combination mode. Select the desired patterns.

Please note a maximum of 20 units stitches can be combined in each module. When the pattern is over 20 units, the warning message will pop out.

Click Combination icon again to return to the single stitch mode.

- ① Combination mode

Note

Stitch patterns that can not be combined, the icon will turn gray and can not be selected.



Add patterns

Click Move icon to move the cursor to the position which you want to add new pattern after it.

Select the pattern you want to insert and add it.

- ① Current pattern
- ② Cursor
- ③ Move to previous pattern
- ④ Move to next pattern
- ⑤ Move to last pattern
- ⑥ Move to first pattern
- ⑦ Number of current pattern/total number of patterns



Delete patterns

Click Move icon to move the cursor to the pattern you want to delete. Click Delete icon to delete it and next pattern will move forward to fill the vacant position.

If you want to delete all patterns, long press Delete icon and the warning message will pop out, click Confirm icon to delete all patterns.

- ① Delete

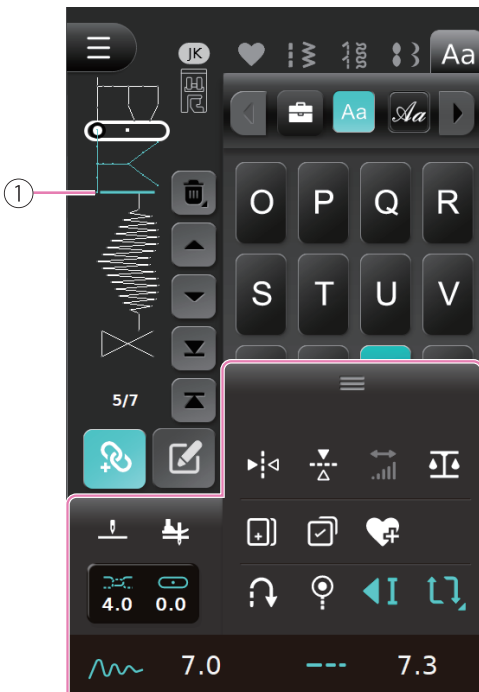

Combination setting

Click Move icon to move the cursor to the pattern you want to change the setting.

To adjust the setting of stitch width, stitch length, tension, mirror, elongation, density and balance calibration, stitch cycling, etc.

- ① Current pattern

Note

If the pattern does not have this function, the icon will turn gray and can not be selected.

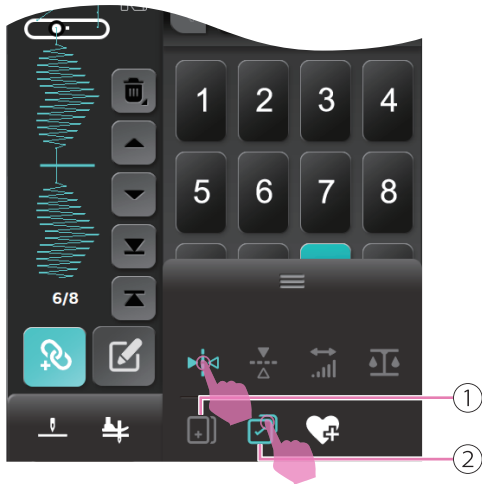

Click Copy icon to copy the previous pattern and all parameter settings of it.

Click Select all icon to select all combination patterns, and it also can set mirror function to all combination patterns at one time.

- ① Copy
- ② Select all

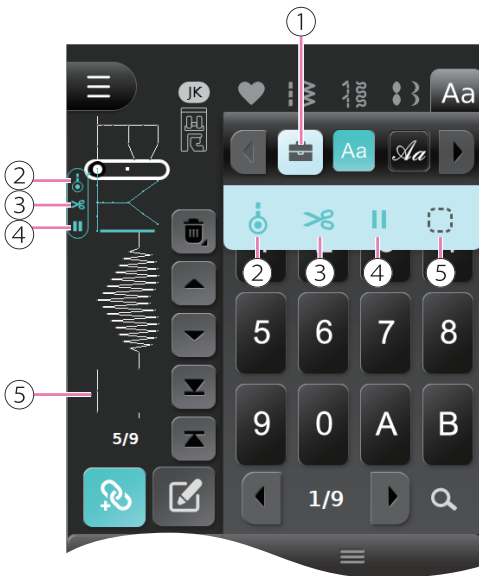

Instructions to set combination patterns

Click Sewing kit icon, you can set up auto-lock, thread cutter, pause, space functions. After start sewing, it will execute the functions.

Move the cursor to the pattern where the functions wants to add, click on the functions icon and the function will add to the desired patterns. Click the functions icon again to cancel the setting.

When auto-lock function is added, it will auto-lock stitches after finish sewing current pattern, then continue to the next pattern.

When thread cutter function is added, it will cut the thread after finish sewing current pattern, then continue to the next pattern.

When pause function is added, it will stop after finish sewing current pattern. This function is helpful for you to add multiple applications on your project.

The order to execute the functions are auto-lock -> thread cutter -> pause.

- ① Sewing kit
- ② Auto-lock
- ③ Thread cutter
- ④ Pause
- ⑤ Space

Note

If the cursor moves to a specific position, the machine will sew from this position.



Creating your own combination pattern

You can create your own stitch in the combination.

Move the cursor to the pattern where you want to replace to your own design stitch, click Edit mode icon to enter design page. After finished the design, it will replace a desired pattern to your own design. Please refer to Chapter "Creating your own pattern" for more information.

① Edit mode

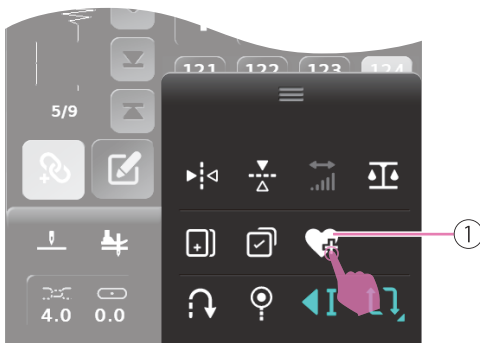

Save combination patterns

When you finish combination patterns, click My favorite icon to save the pattern.

① Add pattern to My favorite

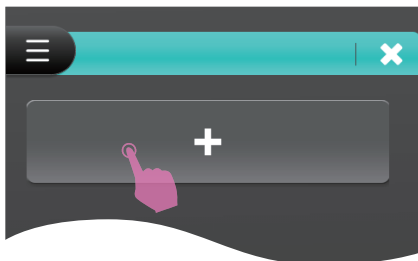

Click the "+" icon to save the pattern.

There are 20 groups of combination patterns can be saved in My favorite program, which creates a quick and easy access at all times.

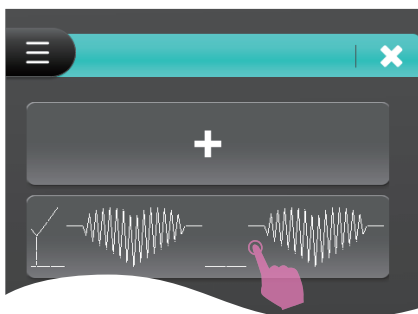

Overwrite combination patterns

Click My favorite icon and go to next page, select the pattern that need to overwrite.

The warning message will pop out, click Confirm icon to overwrite and save the new pattern.

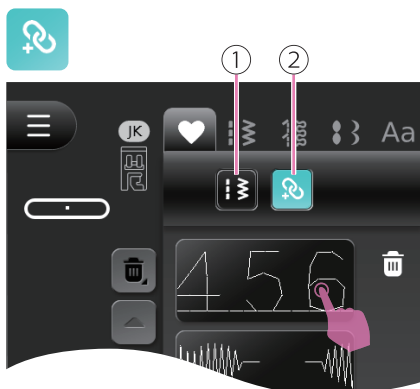

Recall combination patterns

In combination mode, click My Favorite icon to enter setting. Click on Combination pattern icon and select the desired pattern.

- ① Normal pattern
- ② Combination pattern

Press the start/stop button to start sewing.



Delete combination patterns

To delete the saved patterns, click the Delete icon.

- ① Delete



Select the pattern you want to delete.

The warning message will pop out then click Confirm icon to delete the pattern.

Click again the Delete icon, will exit delete mode.

Creating your own pattern

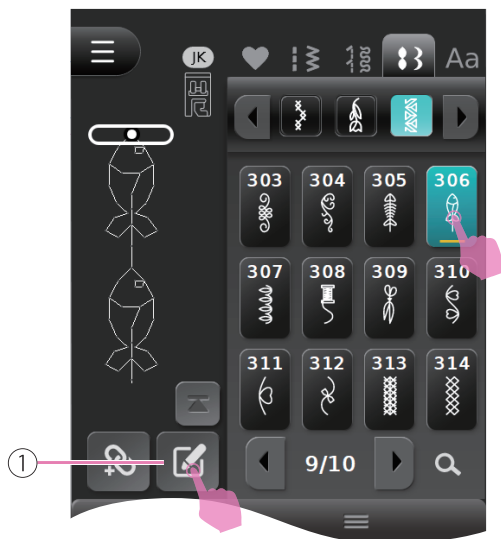

Creating your own pattern allows you to edit existing patterns and create your own unique patterns.

After select the pattern, click on Edit mode icon to enter the design page.

① Edit mode

Note

- Buttonholes and darning stitches are not available in the Edit mode function.
- The created stitch patterns can be saved in "My favorite".

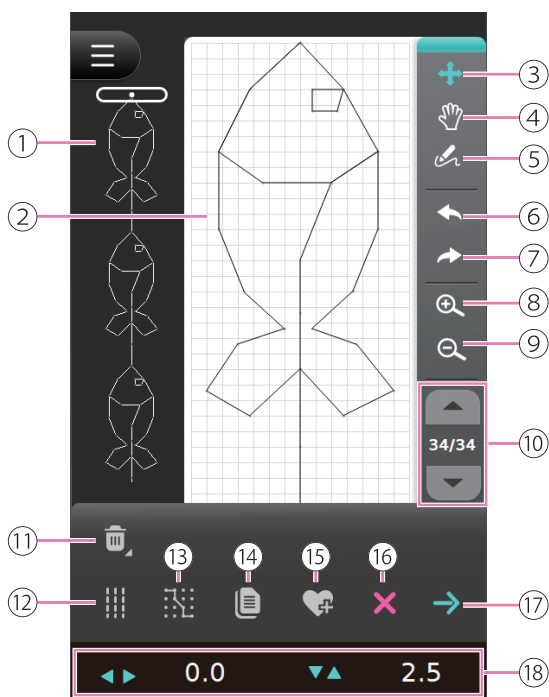

Edit mode icon introduction

- ① Preview screen
- ② Pattern design screen
- ③ Move stitch point
- ④ Drag the object
- ⑤ Drawing the stitch
- ⑥ Undo
- ⑦ Redo
- ⑧ Zoom in
- ⑨ Zoom out
- ⑩ The current stitch / Total stitches
- ⑪ Delete
- ⑫ Triple stitch sewing
- ⑬ Grid
- ⑭ Duplicate
- ⑮ Add current pattern to My favorite
- ⑯ Close (Exit without saving current design)
- ⑰ Confirm
- ⑱ Coordinate

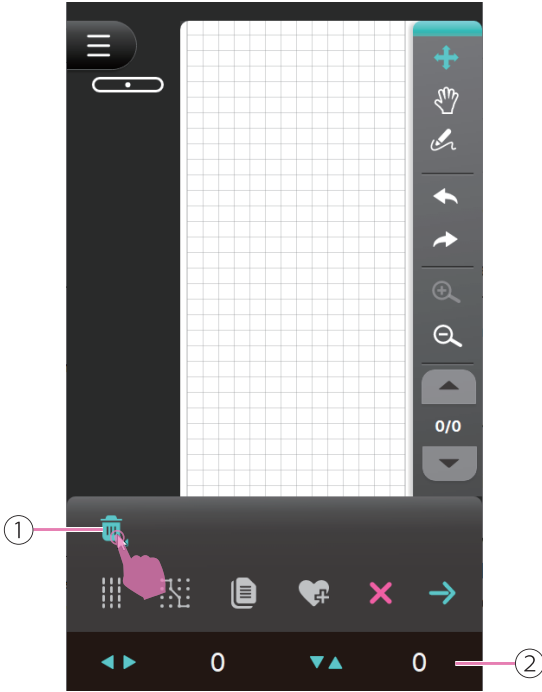

Creating your own pattern

Select the desired pattern and edit, if you want to delete the current design, long press the Delete icon, the warning message will pop out and click Confirm icon to delete it.

The coordinate information of the selected point will display on the bottom screen.

- ① Delete
- ② Coordinate

The stitch width position is the horizontal distance from the selected needle point to the center line(mm). The stitch length position is the vertical distance from the selected stitch point and the previous stitch point(mm).

The designed stitch width is 0.3mm between each needle points. The pattern can design a length up to 70mm. Needle points are limited to 99 points and can no longer be drawn.

Note

- If the designed pattern ends with the reverse stitches or closed (circle) shape, you need to add the pattern from the last stitch point so the design can sew continuously.
- In the preview screen can check if there is a continuously design sewing pattern.

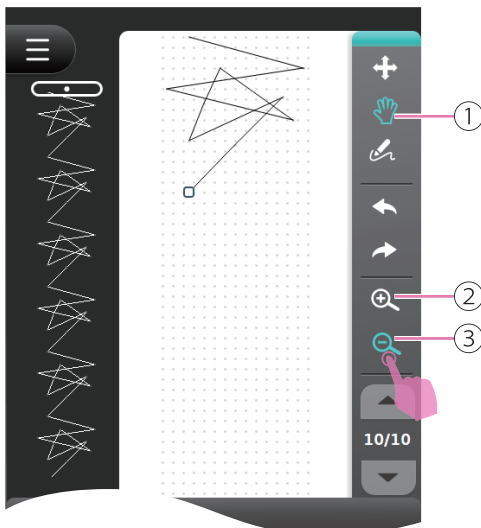

Pattern design screen

Click the Zoom in/Zoom out icon, the pattern design screen will zoom in or zoom out to view the design.

Click Drag the object icon, using stylus or finger to move the design screen.

- ① Drag the object
- ② Zoom in
- ③ Zoom out

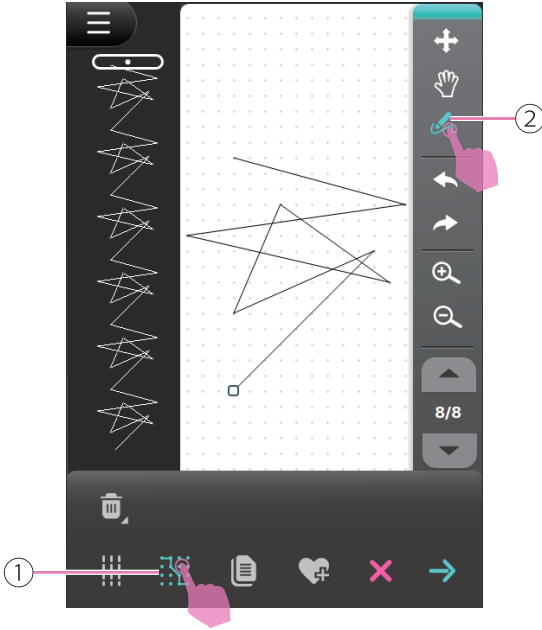

Using Grid to create a pattern

Click the Grid icon, the screen will display grid in line or point.

When it display grid in point, each drawing needle point will automatically snap to the nearest point and created the stitch.

Click Drawing the stitch icon, you can drawing the stitch by using stylus or finger.

- ① Grid (Line/Point)
- ② Drawing the stitch

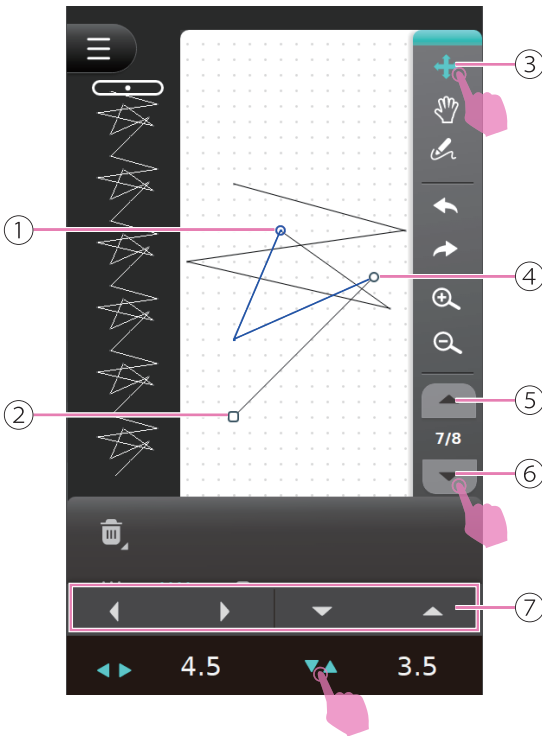

Move stitch point

Click Move stitch point icon, then select the desired point, you can move stitch point by dragging the needle point or click the Direction icon of the coordinate and using control bar to move it.

Click Select multiple needle points upward and down icon, it will select the multiple needle points upward or down from the current stitch point. The selected stitch points will turn blue. You can move stitch points by dragging the blue segment or click the Direction icon of the coordinate and using control bar to move it to the desired position.

- ① Select the starting needle point
- ② The last needle point of the pattern
- ③ Move stitch point
- ④ The current selected needle point
- ⑤ Select multiple needle points upward
- ⑥ Select multiple needle points down
- ⑦ Control bar

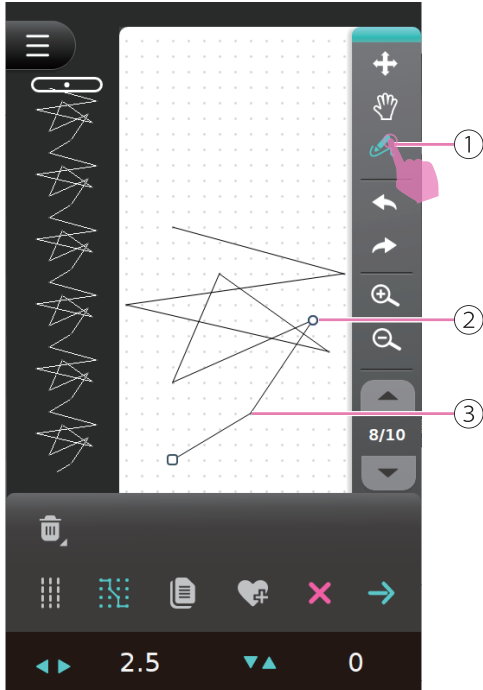

Insert needle point

Click Move stitch point icon, and select the desired point, then click Drawing the stitch icon to insert the needle point. You can insert the needle point by using stylus or finger.

- ① Drawing the stitch
- ② The current selected needle point
- ③ Insert needle point

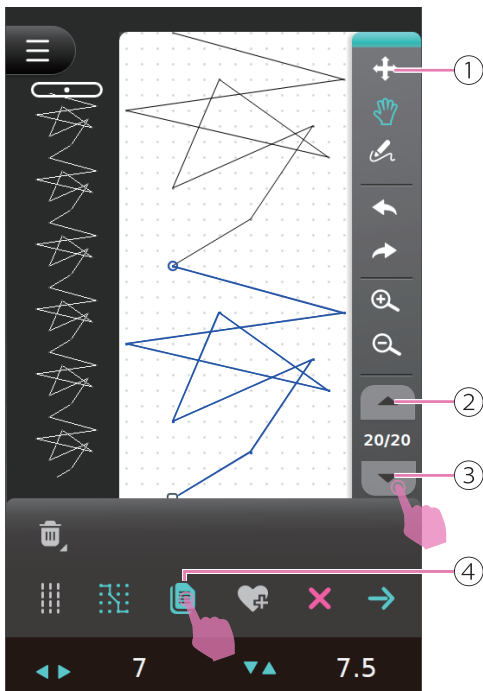

Duplicate needle point

Click Move stitch point icon to select the needle point or click Select multiple needle points upward/downward icon to select the needle points, the selected needle points will turn blue.

Click the Duplicate icon, the selected needle points (blue segment) will copy and insert to the select point.

- ① Move stitch point
- ② Select multiple needle points upward
- ③ Select multiple needle points down
- ④ Duplicate

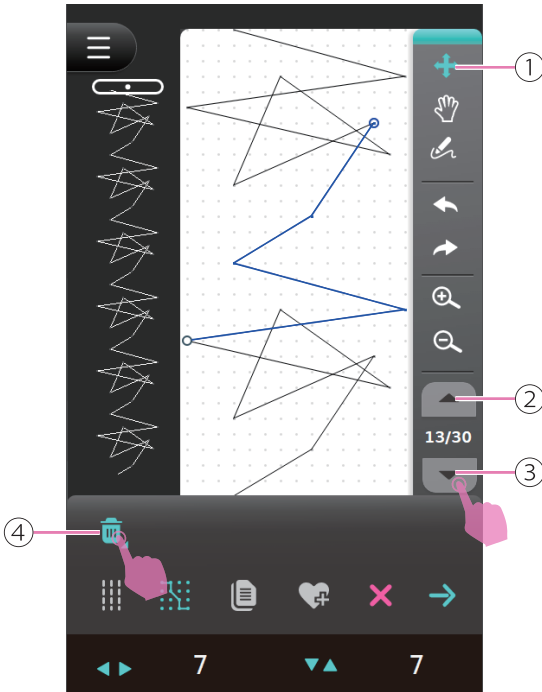

Delete needle point

Click Move stitch point icon to select the needle point or click Select multiple needle points upward/downward icon to select the needle points, the selected needle points will turn blue.

Click the Delete icon, can delete the selected needle points (blue segment). Long press the Delete icon can delete all needle points. The warning message will pop out and click Confirm icon to delete all.

- ① Move stitch point
- ② Select multiple needle points upward
- ③ Select multiple needle points downward
- ④ Delete

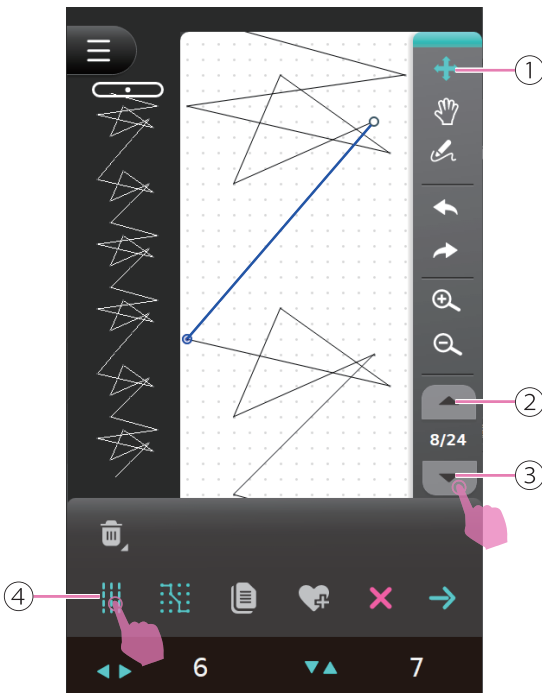

Triple stitch sewing

Click Move stitch point icon to select the needle point or click Select multiple needle points upward/downward icon to select the needle points, the selected needle points will turn blue.

Click the Triple stitch sewing icon, the selected needle points (blue segment) will set to triple stitch sewing. If only select one needle point, the distance between the current and last needle point will set to triple stitch sewing.

Click again the Triple stitch sewing icon to cancel the setting.

- ① Move stitch point
- ② Select multiple needle points upward
- ③ Select multiple needle points downward
- ④ Triple stitch sewing

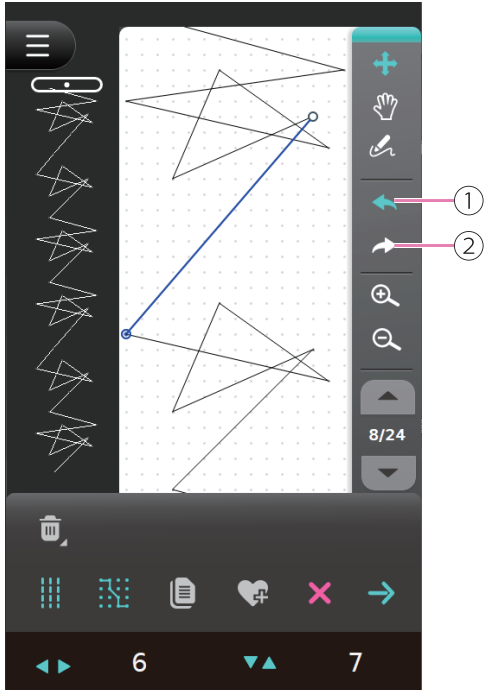

Undo/Redo

Click Undo icon to cancel or reverse the last steps. Click Redo icon to do last steps again.

- ① Undo
- ② Redo

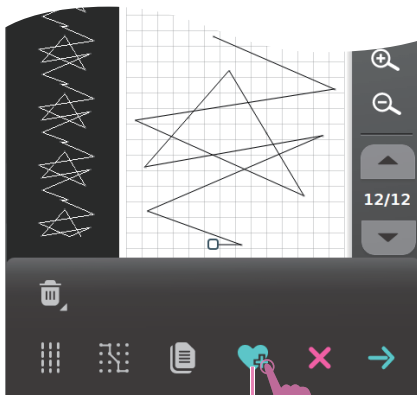

Save Creating pattern to My Favorite

After editing the pattern, click My favorite icon to save the pattern.

To save the pattern, please refer to Chapter "My favorite program" for more information.

- ① Add current pattern to My favorite

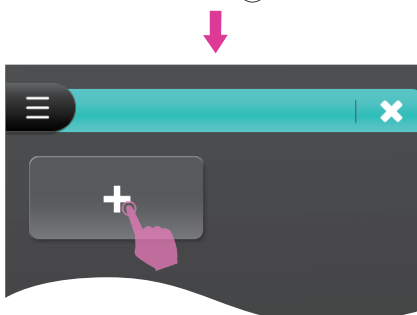



Stitch Chart

Stitch chart

Note

- Patterns 015 & 251 can be used with Wing Needles and will provide best results (Wing needle are not included in the accessories).
- Please do not use Wing Needle in the combination patterns, will not provide good results and may cause danger.

Utility



Buttonholes



Quilting

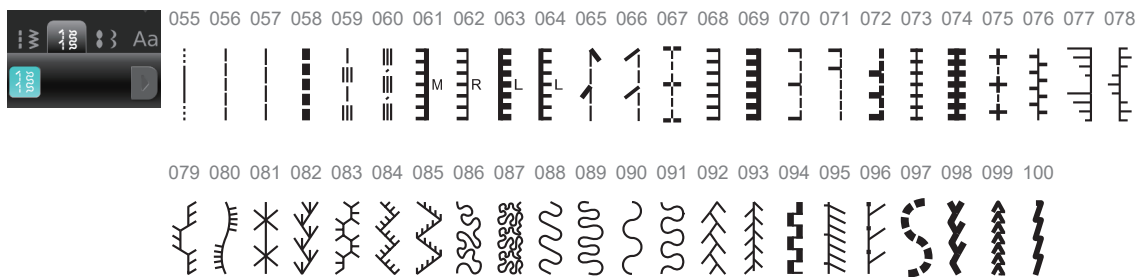

Satin



Decorative_Satin

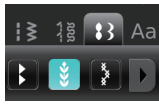

Cross



Florals



Ornamental

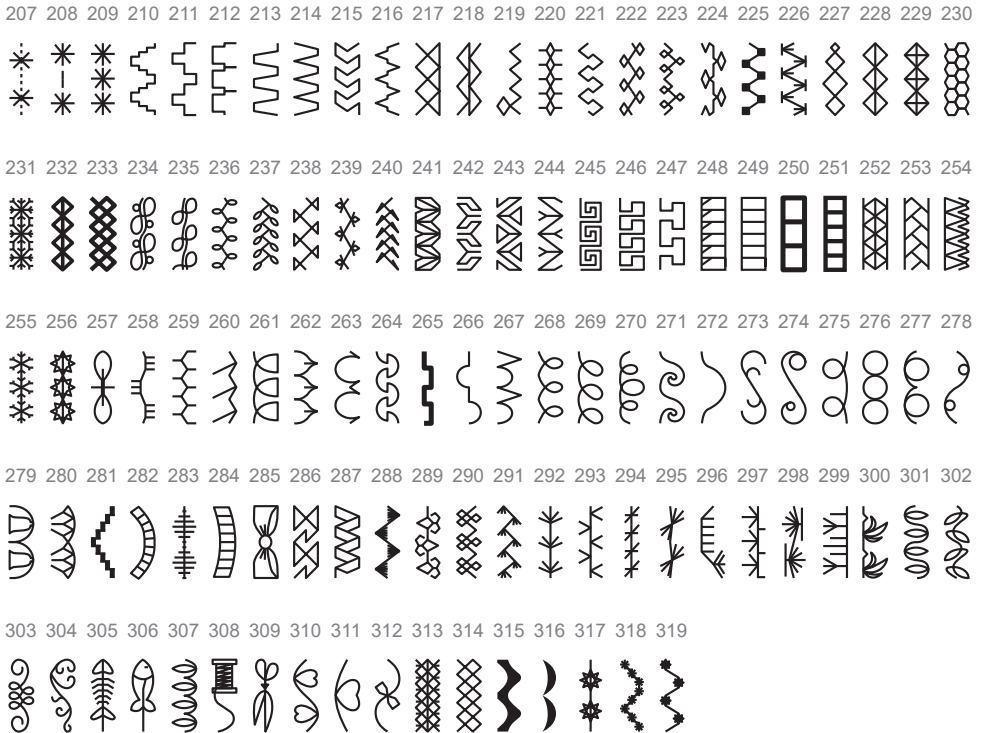

Novelty



320 321 322 323 324 325 326 327 328 329 330 331 332 333 334 335 336 337 338 339 340 341 342 343

344 345 346 347 348 349 350

Alphabet-block style



01 02 03 04 05 06 07 08 09 10 11 12 13 14 15 16 17 18 19 20 21 22 23 24

1 2 3 4 5 6 7 8 9 0 A B C D E F G H I J K L M N

25 26 27 28 29 30 31 32 33 34 35 36 37 38 39 40 41 42 43 44 45 46 47 48

O P Q R S T U V W X Y Z a b c d e f g h i j k l

49 50 51 52 53 54 55 56 57 58 59 60 61 62 63 64 65 66 67 68 69 70 71 72

m n o p q r s t u v w x y z Ä Å Æ Ñ Ö Ø Ç Ü ä å

73 74 75 76 77 78 79 80 81 82 83 84 85 86 87 88 89 90 91 92 93 94 95 96

à æ ë è é ê ñ ö õ ø ì ç ü ù ß & ? ! ' , . - ()

97 98 99

@ + =

Alphabet-script style



01 02 03 04 05 06 07 08 09 10 11 12 13 14 15 16 17 18 19 20 21 22 23 24

1 2 3 4 5 6 7 8 9 0 A B C D E F G H I J K L M N

25 26 27 28 29 30 31 32 33 34 35 36 37 38 39 40 41 42 43 44 45 46 47 48

o P Q R S T U V W X Y Z a b c d e f g h i j k l

49 50 51 52 53 54 55 56 57 58 59 60 61 62 63 64 65 66 67 68 69 70 71 72

m n o p q r s t u v w x y z Ä Å Æ Ñ Ö Ø Ç Ü ä å

73 74 75 76 77 78 79 80 81 82 83 84 85 86 87 88 89 90 91 92 93 94 95 96

à æ ë è é ê ñ ö õ ø ì ç ü ù ß & ? ! ' , . - ()

97 98 99

@ + =

Alphabet-outline style

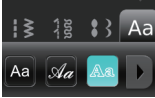
| | | | | | | | | | | | | | | | | | | | | | | | | |
|---|----|----|----|----|----|----|----|----|----|----|----|----|----|----|----|----|----|----|----|----|----|----|----|----|
|  | 01 | 02 | 03 | 04 | 05 | 06 | 07 | 08 | 09 | 10 | 11 | 12 | 13 | 14 | 15 | 16 | 17 | 18 | 19 | 20 | 21 | 22 | 23 | 24 |
| | 1 | 2 | 3 | 4 | 5 | 6 | 7 | 8 | 9 | 0 | A | B | C | D | E | F | G | H | I | J | K | L | M | N |
| | 25 | 26 | 27 | 28 | 29 | 30 | 31 | 32 | 33 | 34 | 35 | 36 | 37 | 38 | 39 | 40 | 41 | 42 | 43 | 44 | 45 | 46 | 47 | 48 |
| | O | P | Q | R | S | T | U | V | W | X | Y | Z | a | b | c | d | e | f | g | h | i | j | k | l |
| | 49 | 50 | 51 | 52 | 53 | 54 | 55 | 56 | 57 | 58 | 59 | 60 | 61 | 62 | 63 | 64 | 65 | 66 | 67 | 68 | 69 | 70 | 71 | 72 |
| | m | n | o | p | q | r | s | t | u | v | w | x | y | z | Ä | Å | Æ | Ñ | Ö | Ø | Ç | Û | ä | å |
| | 73 | 74 | 75 | 76 | 77 | 78 | 79 | 80 | 81 | 82 | 83 | 84 | 85 | 86 | 87 | 88 | 89 | 90 | 91 | 92 | 93 | 94 | 95 | 96 |
| | à | æ | ë | è | é | ê | ñ | ö | õ | ø | ì | ç | û | ü | ß | & | ? | ! | ' | , | . | - | (|) |
| | 97 | 98 | 99 | | | | | | | | | | | | | | | | | | | | | |
| | @ | + | = | | | | | | | | | | | | | | | | | | | | | |

Alphabet-Russian style

| | | | | | | | | | | | | | | | | | | | | | | | | |
|---|----|----|----|----|----|----|----|----|----|----|----|----|----|----|----|----|----|----|----|----|----|----|----|----|
|  | 01 | 02 | 03 | 04 | 05 | 06 | 07 | 08 | 09 | 10 | 11 | 12 | 13 | 14 | 15 | 16 | 17 | 18 | 19 | 20 | 21 | 22 | 23 | 24 |
| | 1 | 2 | 3 | 4 | 5 | 6 | 7 | 8 | 9 | 0 | А | Б | В | Г | Д | Е | Ё | Ж | З | И | Й | К | Л | М |
| | 25 | 26 | 27 | 28 | 29 | 30 | 31 | 32 | 33 | 34 | 35 | 36 | 37 | 38 | 39 | 40 | 41 | 42 | 43 | 44 | 45 | 46 | 47 | 48 |
| | Н | О | П | Р | С | Т | У | Ф | Х | Ц | Ч | Ш | Щ | Ъ | Ы | Ь | Э | Ю | Я | а | б | в | г | д |
| | 49 | 50 | 51 | 52 | 53 | 54 | 55 | 56 | 57 | 58 | 59 | 60 | 61 | 62 | 63 | 64 | 65 | 66 | 67 | 68 | 69 | 70 | 71 | 72 |
| | е | ё | ж | з | и | й | к | л | м | н | о | п | р | с | т | у | ф | х | ц | ч | ш | щ | ъ | ы |
| | 73 | 74 | 75 | 76 | 77 | 78 | 79 | 80 | 81 | 82 | 83 | 84 | 85 | 86 | 87 | 88 | 89 | 90 | 91 | 92 | 93 | 94 | 95 | 96 |
| | ь | э | ю | я | / | < | > | « | » | (|) | \$ | @ | & | % | ' | , | ' | . | _ | - | + | = | : |
| | 97 | 98 | 99 | | | | | | | | | | | | | | | | | | | | | |
| | ; | ? | ! | | | | | | | | | | | | | | | | | | | | | |



Sewing Basics

Starting to sew

Make sure you follow the needle/fabric/thread combinations and use the suggested presser foot before sewing.

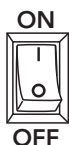

1. Turn the power switch to on ("I").

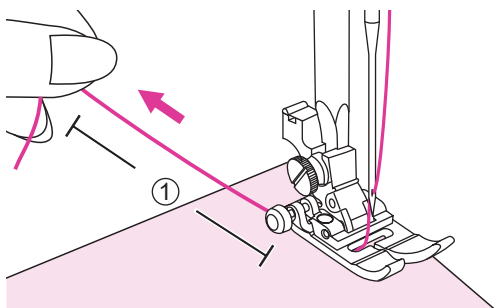

2. Place the fabric under the presser foot, pass the thread under the presser foot, and then pull out about 10cm of thread toward the rear of the machine.

① 10cm

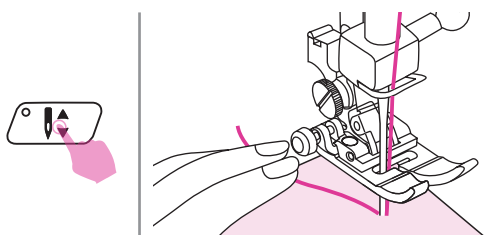

3. Press the needle up/down position button to lower the needle into the fabric at the beginning of the stitching.

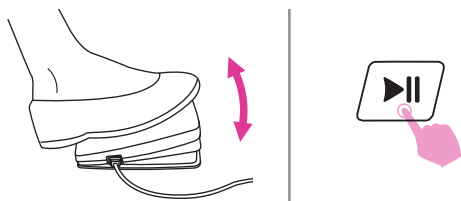

4. Slowly press down the foot control or long press the start/stop button to start sewing, presser foot will automatically lower at the same time.

Release the foot control or press the start/stop button again to stop the machine.

Note

You can use reverse sewing for back tacking and reinforcing seams by pressing the reverse button. Please refer to "Useful skills" chapter for more information.

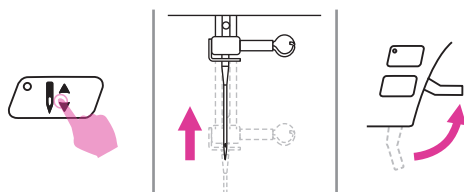

5. Press the needle up/down position button to raise the needle. Raise the presser foot lifter and remove the fabric.

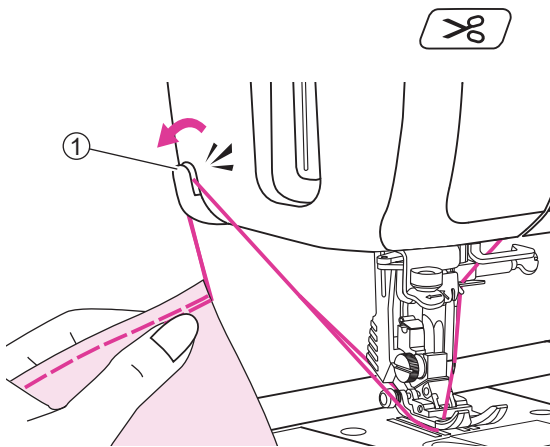

6. Press the thread cutter button to trim the threads.
Or guide both threads to the side of the face plate and into the thread cutter to cut them.

① Thread cutter

Useful skills

Various ways to achieve better results for your sewing projects are described below. Refer to these tips when sewing your project.

The results depend on types of fabrics and stitches. Please use the same fabric of the project and do a sewing test in advance.

For the trial sewing, use a piece of fabric and thread that are same as those used for your project and check the thread tension and stitch length and width.

Since the results differ depending on types of stitching and layers of fabric sewn, perform the trial sewing under the same conditions that will be used with your project.

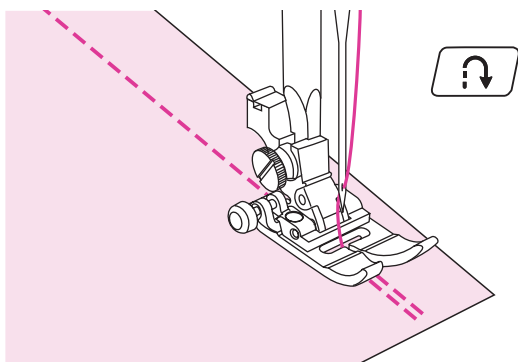

Reverse sewing

Reverse stitching is used to secure the threads at the beginning and at the end of a seam.

Press the reverse button and sew 4-5 stitches.

The machine will sew forward when the button is released.

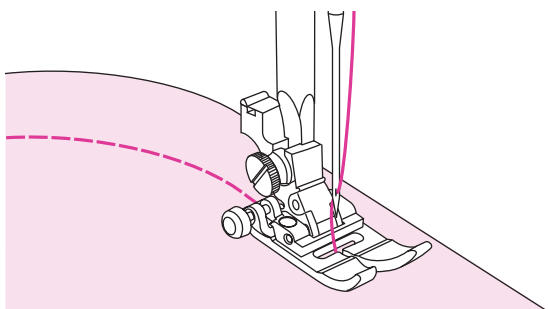

Sewing curves

Slightly change the sewing direction to sew around the curve.

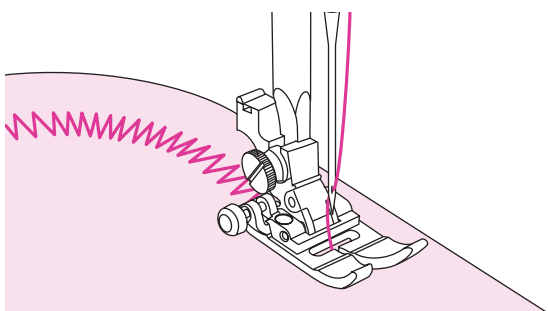

When sewing along a curve while using a zigzag stitch, select a shorter stitch length in order to obtain a finer stitch.

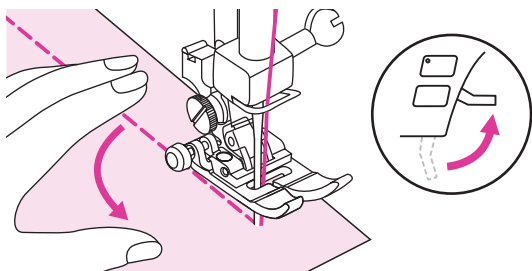

Sewing corners

Stop the sewing machine when you reach a corner.

Lower the needle into the fabric. Raise the presser foot lifter. Use the needle as a pivot and turn the fabric 90°.

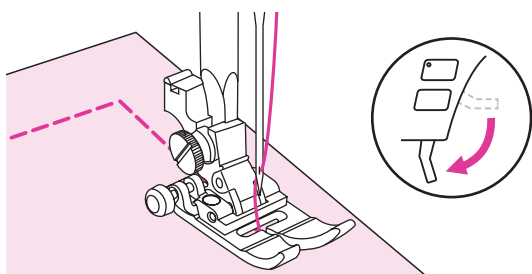

Lower the presser foot lifter and resume sewing.

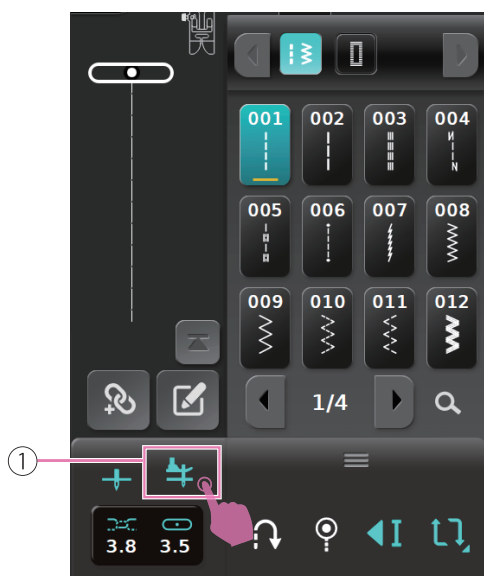

When you want to change the sewing direction, you can also set the pivot function in the sewing mode. When you stop sewing, the needle will stay in the fabric, and presser foot will automatically lift, which can easily rotate the fabric. This function is very useful. (Presser foot height setting, please refer to "setting" chapter for more information.)

① Pivot setting

Note

- After setting the pivot function, the machine will automatically set the needle position down when sewing stops.
- If the needle position is set to be up, the pivot setting will be canceled simultaneously.

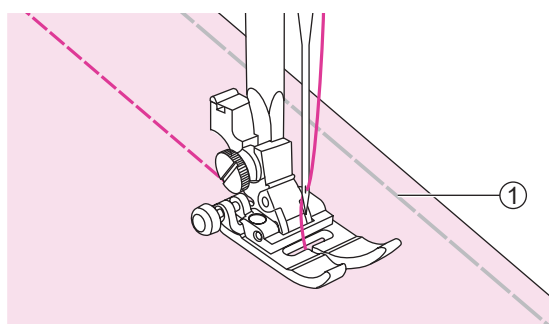

Sewing stretch fabrics

Baste the pieces of fabric together, and then sew without stretching the fabric.

① Basting

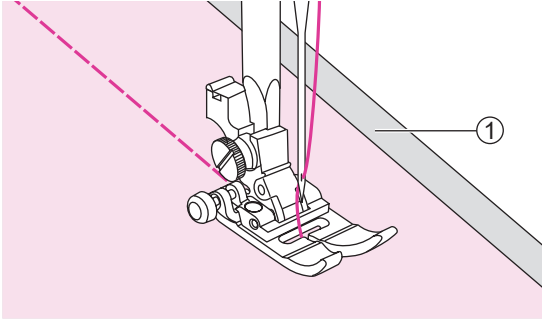

Sewing thin fabrics

When sewing thin fabrics, the stitches may become misaligned or the fabric may not feed correctly. If this occurs, place thin paper or stabilizer material under the fabric and sew it together with the fabric.

When you have finished sewing, tear off any excess paper.

① Stabilizer material or paper

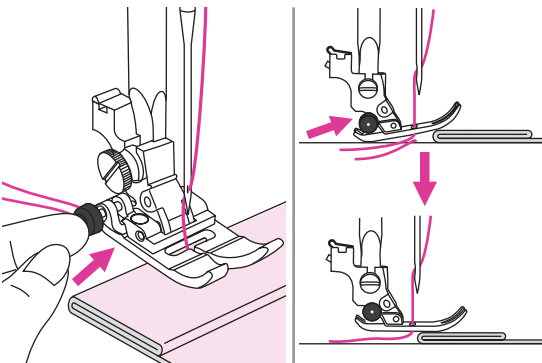

Sewing heavy fabric

The black button on the left side of the presser foot will lock the presser foot in a horizontal position if you push it in before lowering the presser foot.

This ensures even feeding at the beginning of a seam and helps when sewing multiple layers of fabrics such as sewing over seams when hemming jeans.

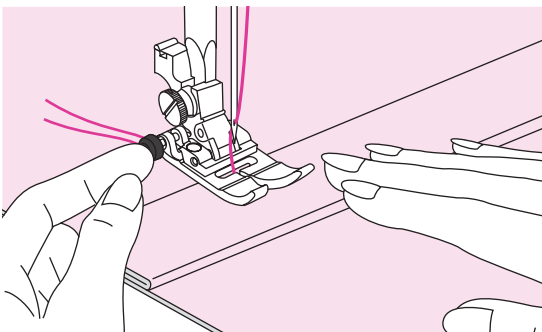

When you reach the point of an increased thickness, lower the needle and raise the presser foot lifter. Press the toe of the foot to the horizontal line and push in the black button, then lower the foot and continue sewing.

The black button releases automatically after sewing few stitches.

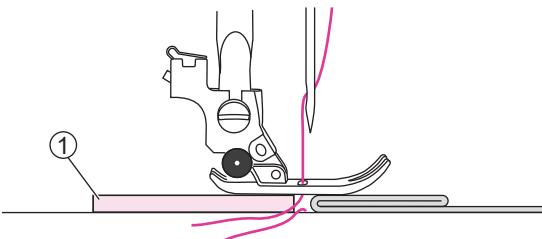

You also can place another piece of fabric with the same thickness at the back of the seam. Or support the presser foot while feeding by hand and sewing toward the folded side.

① Cardboard or thick fabric



Utility Stitches

Automatic lock stitch

Automatic lock stitch, it will automatically lock stitches at the beginning and end of sewing to secure the thread.

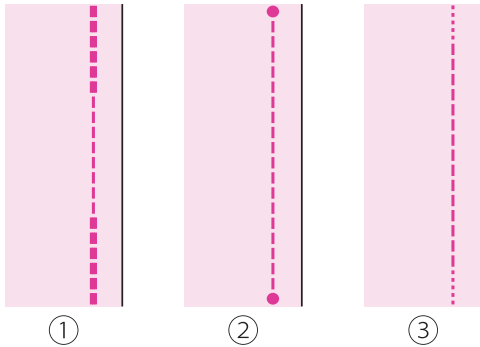
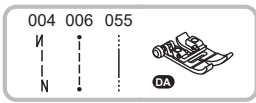

Depending on the stitch pattern chosen, there are different methods of lock stitches.

- ① 004 : First move forward and then backward to make up the lock stitches, it is suitable for general joint seams.
- ② 006 : Lock stitch in the same place, it is suitable for patchwork applications.
- ③ 055 : Slight forward lock stitch, it is suitable for patchwork applications.

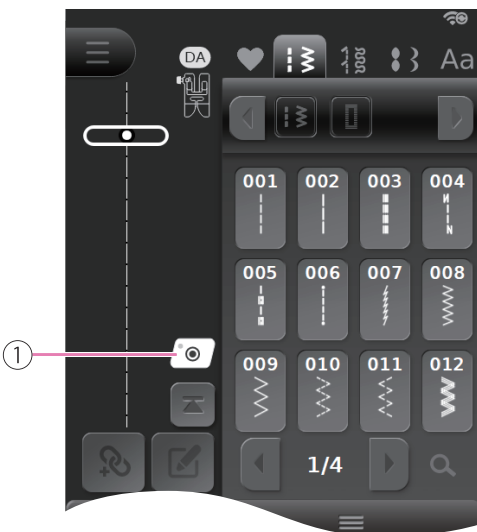

Press the start/stop button to start sewing. The machine will first lock stitches at the beginning.

The screen will display a reminder with a lock stitch icon which means after sewing to the desired length, need to press the auto-lock button from the machine, then will perform lock stitch at the end of the sewing and stop.

- ① Lock stitch button reminder



Stretch stitch

Use this stitch with knitted tricot or other stretchy fabrics. The stitch enables your seam to stretch without breaking the thread.

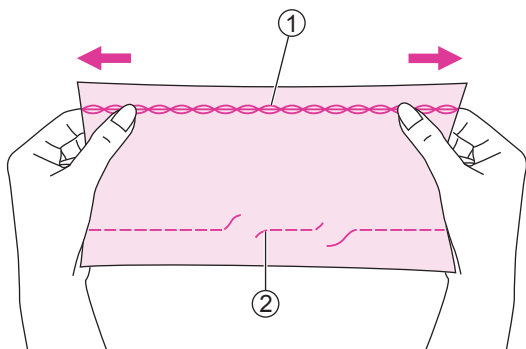

Good for easy to ravel and knit fabrics. It's good for joining durable fabric such as denims.

These stitches can also be used as a decorative top stitches.

- ① Stretch stitch
- ② Straight stitch

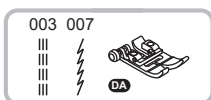

Using the all purpose foot.

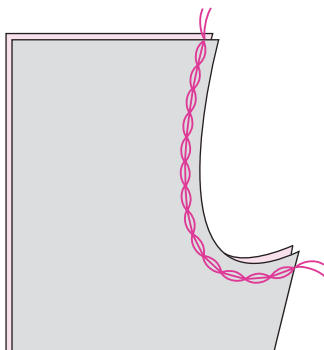

Straight stretch stitch

Straight stretch stitch is used to add triple reinforcement to stretch and hardwearing seams.

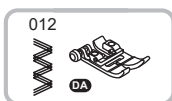

Using the all purpose foot.

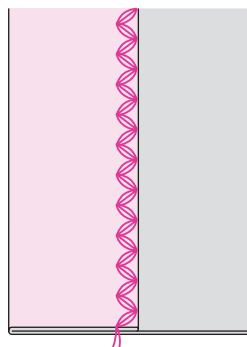

Zigzag stretch stitch

Triple zigzag stretch stitch is suitable for firm fabrics like denim, poplin, etc.

Sewing stretch fabrics and elastic tape

When elastic tape is attached to the cuff or waist of a piece of clothing, the finished dimensions will be that of the stretched elastic tape. Therefore, it is necessary that a suitable length of the elastic tape be used.

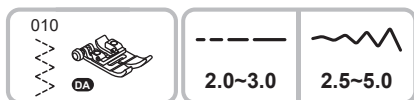

Using the all purpose foot.

Pin the elastic tape to the wrong side of fabric at a few points to make sure that the tape is uniformly positioned on the fabric.

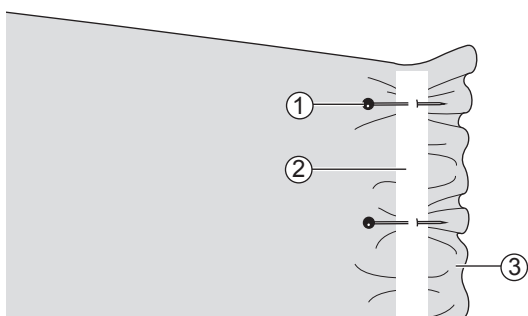

- ① Pin
- ② Elastic tape
- ③ Wrong side

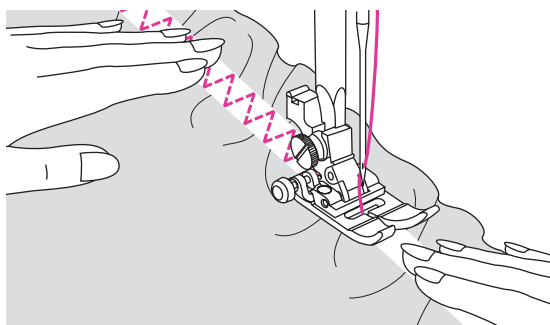

Sew the elastic tape to the fabric while stretching the tape so that it is the same length as the fabric.

While pulling the fabric behind the presser foot with your left hand, pull the fabric at the pin nearest the front of the presser foot with your right hand.

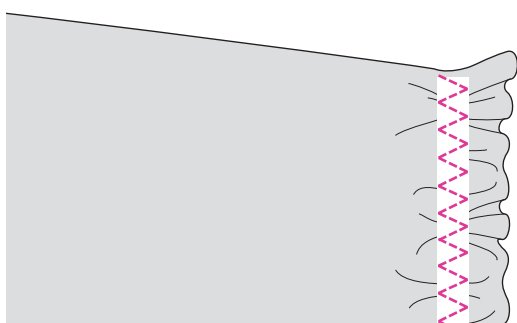

Note

When sewing, be sure that the needle does not touch any pins, otherwise the needle may bend or break.

Overcasting stitch

Sewing overcasting stitches along the edge of fabric to prevent it from fraying.

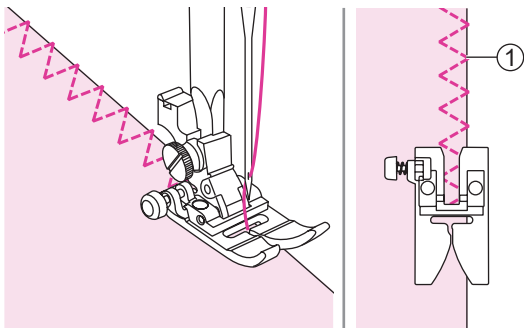

Using the all purpose foot

Attach the all purpose foot.

Sew the overcasting along the edge of the fabric so that the needle drops over the edge of the fabric on the right side.

- ① Needle drop point

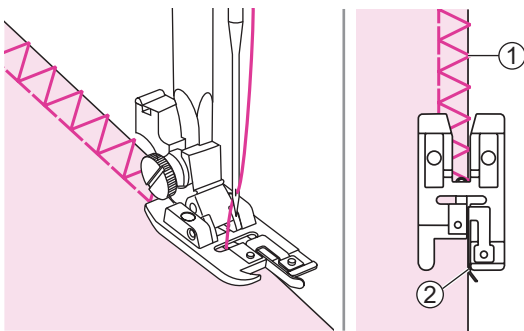
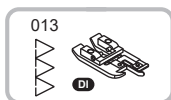

Using the overcasting foot

Attach the overcasting foot.

Sew the fabric with the fabric edge against the guide of the overcasting foot.

- ① Needle drop point
- ② Guide

Blind Hem

Secure the bottom of skirts and pants with a blind hem, this stitch will sew with invisible stitch on the right side of the fabric.

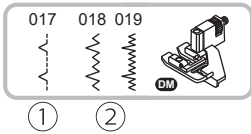

Using the blind hem foot.

- ① Blind hem/lingerie for firm fabrics.
- ② Blind hem for stretch fabrics.

Note

Please use the same fabric of the project and do a sewing test in advance.

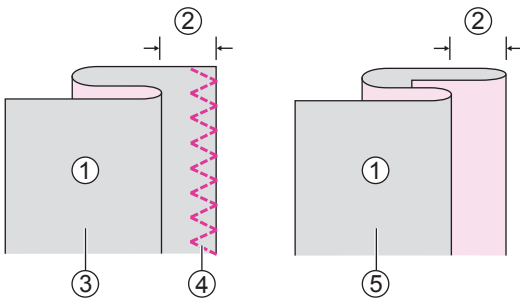

Fold the fabric as illustrated with the wrong side up.

- ① Wrong side
- ② 5mm
- ③ For heavy weight fabric
- ④ Overcasting stitch
- ⑤ For light/medium weight fabric

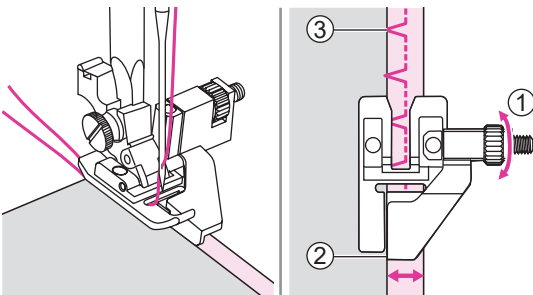

Place the fabric under the foot. Turn the handwheel forwards until the needle swings fully to the left. It should just pierce the fold of the fabric. If it does not, adjust the stitch width accordingly. Adjust the guide by turning the knob so that the guide just rests against the fold.

- ① Knob
- ② Guide
- ③ Needle drop point

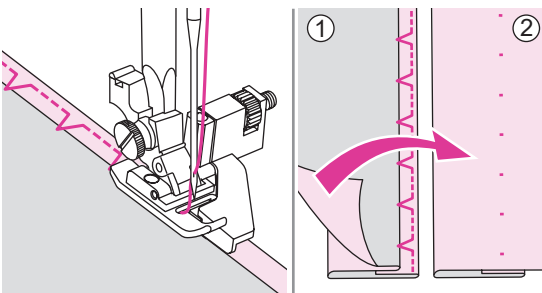

Sew slowly, guiding the fabric carefully along the edge of the guide.

Turn over the fabric.

- ① Wrong side
- ② Right side

Buttonhole stitch

Buttonholes can be adapted to the size of the button.

For stretch fabric or thin fabric, it is recommended to use a stabilizer for a better buttonhole sewing. Slightly reduce upper thread tension to produce better results.

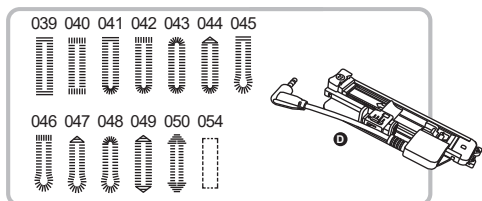

Using the electronic buttonhole foot.

039/041/043: For thin or medium fabric

045/046: For suits or overcoats

040/042: Heavy-duty buttonholes with vertical bar tacks

044/049/050: Reinforced waist tapered buttonhole

047/048: For jeans or trousers

054 : Program for staystitching buttonholes, for pocket openings, reinforcing buttonholes: especially for buttonholes in leather and imitation leather

Note

Please use the same fabric of the project and do a sewing test in advance.

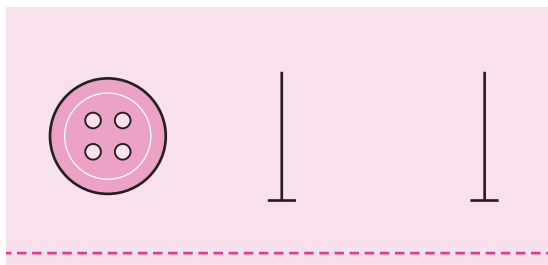

Mark the positions of the buttonhole on the fabric.

The maximum buttonhole length is 3cm. (Total of diameter + thickness of button.)

The size of the buttonhole is determined by the button inserted in the button plate.

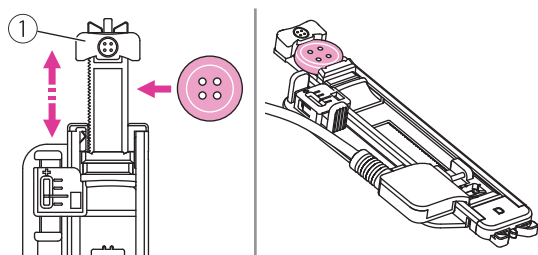

Pull the button holder plate to the back, and place the button in it. Push back the button holder plate against the button to hold it tight.

① Button holder plate

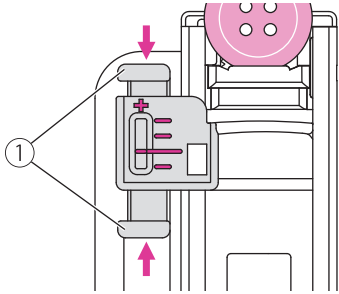

Consider the shape and height of each button, buttonhole fine tuning adjuster provides fine adjustment of the buttonhole length.

- ① Buttonhole fine tuning adjuster

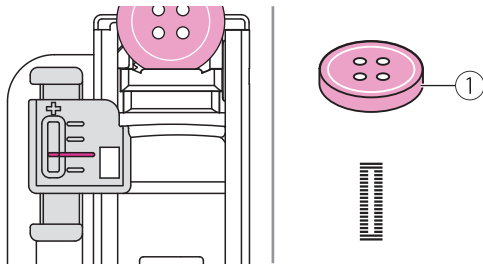

The red mark is the standard setting for regular button, adjust the pointer align with the red mark.

- ① Regular button

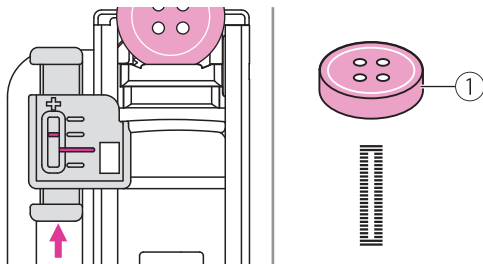

The buttonhole length may need to be increased for thick button, adjust the pointer toward to "+" for fine tuning.

- ① Thick button

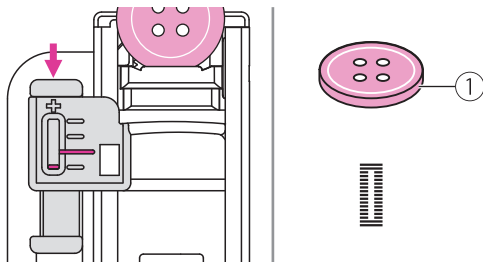

The buttonhole length may need to be decreased for thin button, adjust the pointer toward to "-" for fine tuning.

- ① Thin button

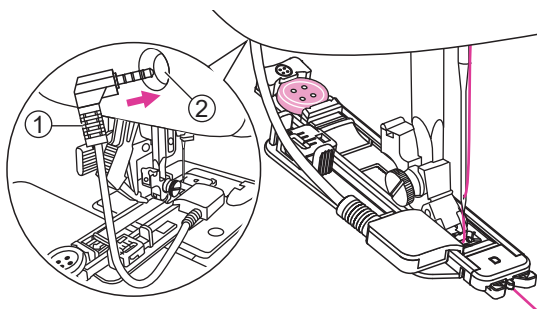

Attach the electronic buttonhole foot and plug the cord into the socket behind the face cover.

The upper thread should be passed through the hole of electronic buttonhole foot and bring the upper thread to the front of electronic buttonhole foot.

- ① Cord
- ② Socket

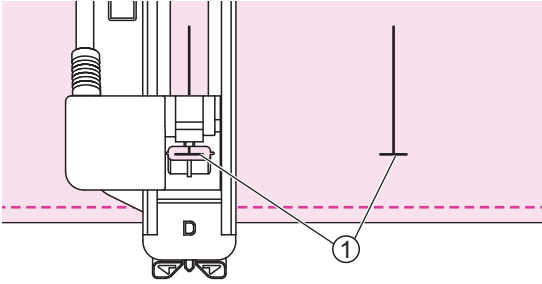

Position the fabric under the presser foot so that the centerline's mark is aligning with the center of the buttonhole foot.

① Starting point

Select the buttonhole stitch. Adjust the stitch width and the stitch length to the desired width and density.

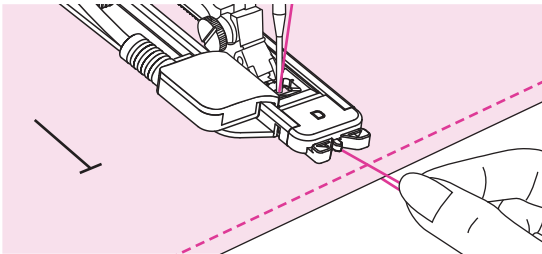

Slightly hold the end of the upper thread and start sewing. Pull two lines together.

Note

- Gently feed the fabric by hand.
- Before stopping, the machine will automatically sew a reinforcement stitch after the buttonhole is sewn.

When you finish sewing, raise the presser foot lifter and cut the thread. To sew over the same buttonhole, raise the presser foot lifter.

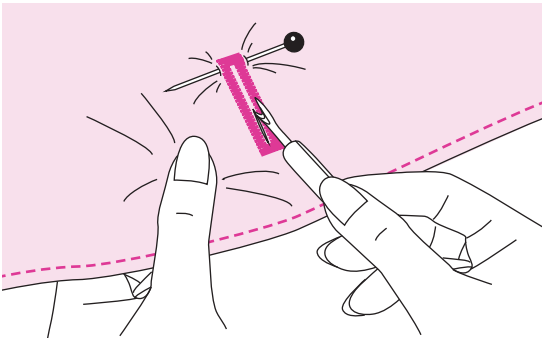

Use the seam ripper to cut the center of the buttonhole being careful not to cut any stitches on either side. Use a pin as a stopper at the bar tack so you do not cut too much.

Note

When cutting the buttonhole with the seam ripper, do not place your hands in the cutting direction, otherwise injuries may result.

Making a buttonhole on stretch fabrics

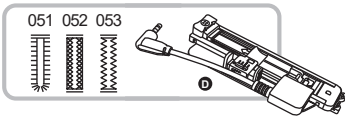

051: For light to medium weight woven fabrics

052: For stretch fabric

053: For stretch or woven fabric

When sewing buttonholes on stretch fabric, hook heavy thread or cord under the buttonhole foot.

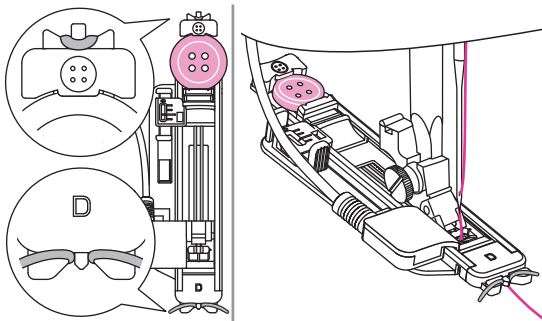

Attach the electronic buttonhole foot and plug the cord into the socket above the presser foot bar. Bring the gimp thread ends to the front of the foot and insert them into the grooves, then tie them there temporarily. Lower the presser foot lifter and start sewing.

Set the stitch width to match the diameter of the gimp thread.

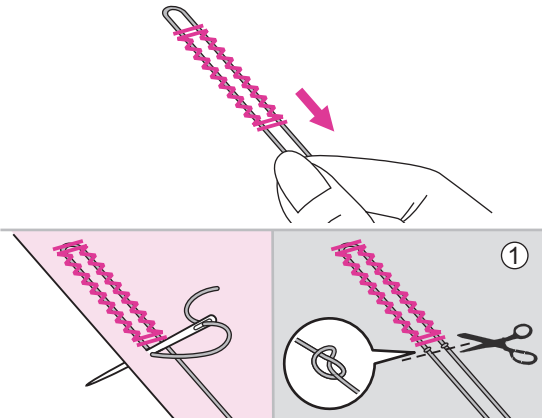

Once sewing is completed, pull the gimp thread gently to remove any slack. Cross the gimp in front of the needle and thread gimp ends into a large needle, pull to the wrong side and knot ends before cutting excess.

① Wrong side

Note

It is suggested that you sew with a stabiliser material under the fabric.

* Buttonholes are sewn from the front of the presser foot to the back, as shown.

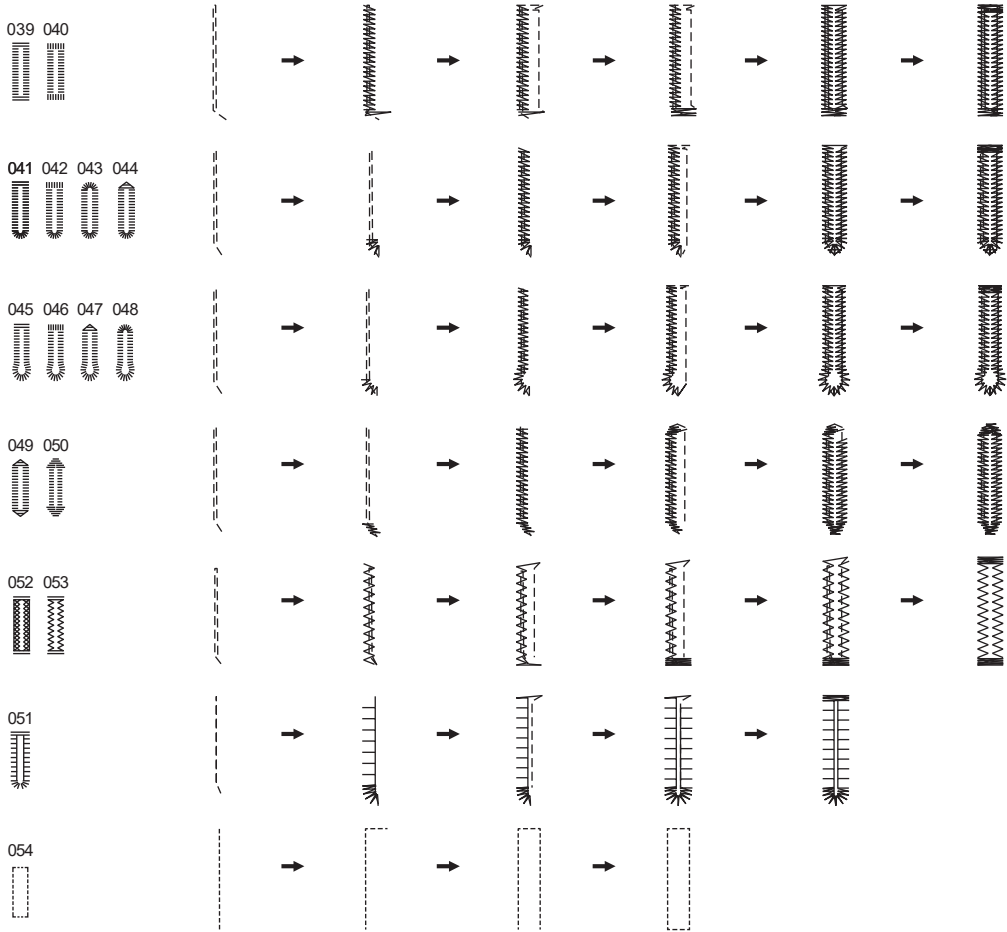

Bar tack stitch

Bar tack stitch is used to reinforce points subject to strain, such as pocket corners and openings.

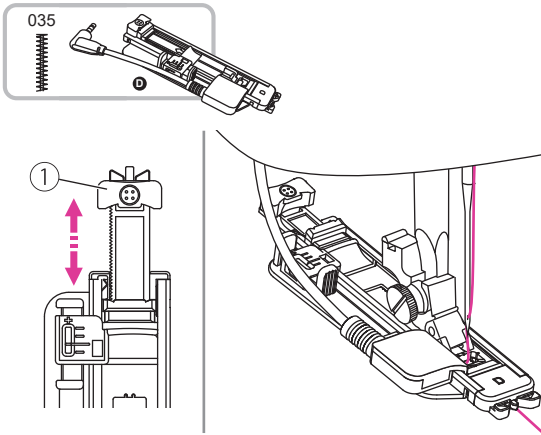

Using the electronic buttonhole foot.

Extend the button holder plate and set to the desired length. Adjust the stitch width and the stitch length to the desired width and density.

① Button holder plate

Attach the electronic buttonhole foot and plug the cord into the socket above the presser foot bar.

The upper thread should be passed through the hole of electronic buttonhole foot and bring the upper thread to the front of electronic buttonhole foot.

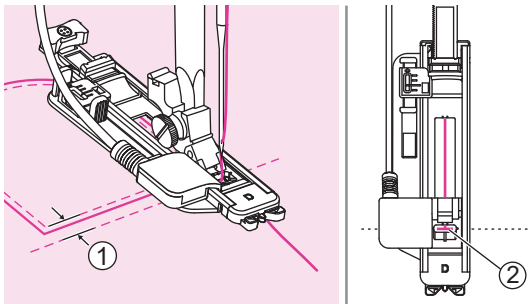

Position the fabric so that the needle is 2mm in front of where you want the sewing to start, and then lower the presser foot lifter.

- ① 2mm
- ② Starting point

Slightly hold the end of the upper thread and start sewing.

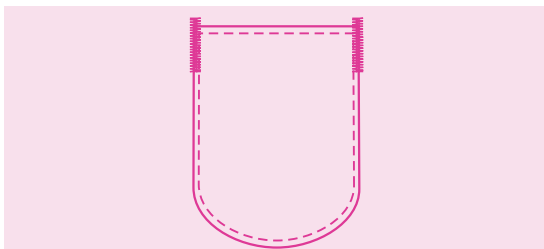

Bar tack stitches are sewn.

Note

It is suggested that you sew with a stabilizer material under the fabric.



Darning stitches are sewn from the front of the presser foot to the back, as shown.

Note

If the fabric does not feed, for example, because it is too thick, increase the stitch length.

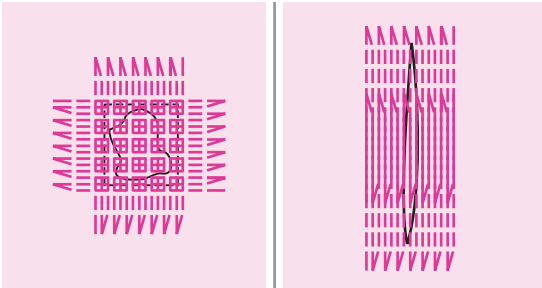

If the sewing range is too big to sew, then we suggest you can sew several times (or cross sew) to get better sewing result.

Eyelet stitch

Eyelet stitches are used for making belt holes and other similar applications.

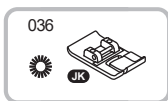

Using the satin stitch foot.

Press the "+" or "-" button to alter the size of the eyelet.

Lower the needle into the fabric at the beginning of the stitching, and then lower the presser foot lifter.

Once sewing is completed, the machine automatically sews reinforcement stitches, then stops.

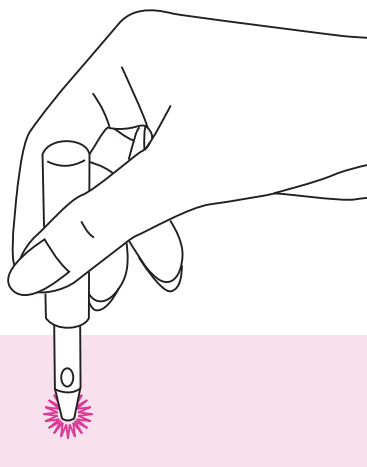

Make a hole at the center using an eyelet punch.

* Eyelet punch is not included with the machine.

Note

- When using the eyelet punch, place thick paper or some other protective sheet under the fabric before punching the hole in the fabric.
- If thin thread is used, the stitching may be coarse. If this occurs, sew the eyelet twice one on top of the other.

Button sewing

Buttons can be sewn on with the sewing machine. Buttons with 2 or 4 holes can be attached.

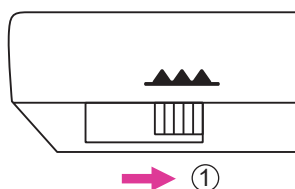
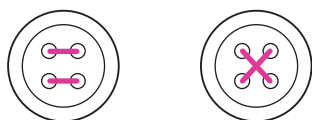
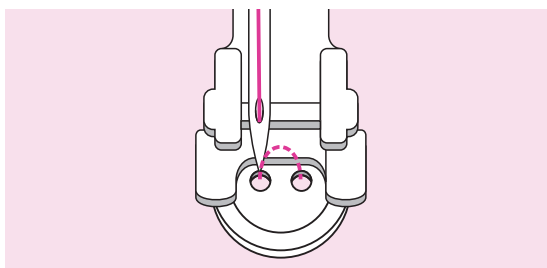
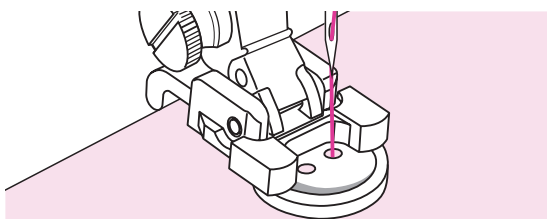
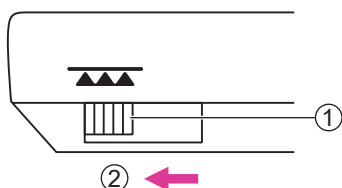
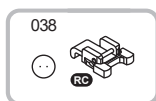

Using the button sewing foot.

Move the drop feed lever to lower the feed dogs.

- ① Drop feed lever
- ② Lowered position

Put the work under the foot and place the button in desired position, then lower the foot.

Select the buttonhole sewing stitch and adjust the stitch width according to the distance between the two holes of the button.

Turn the handwheel to check that the needle goes cleanly into the left and right holes of the button.

For buttons with 4 holes, sew through the front two holes first, push work forward and then sew through the back two holes.

When you finish the work, move the drop feed lever to raise the feed dogs.

- ① Raised position

Zipper insertion

This foot can be set to sew on each side of the zipper, the edge of the foot guides the zipper to ensure straight placement.

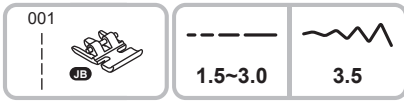

Using the zipper foot.

△ Attention

- Zipper foot should be used for sewing straight stitches only. It is possible that the needle could hit the presser foot and break when sewing other stitches.
- When sewing, be sure that the needle does not touch the zipper, otherwise the needle may bend or break.

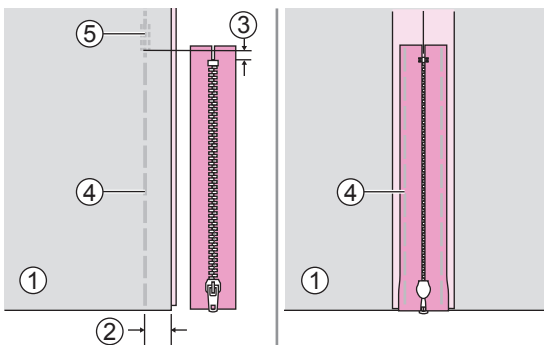

Inserting a centered zipper

Place the right sides of the fabric together. Sew a bottom seam 2cm from the right edge of the zipper bottom stop position. Sew few reverse stitches for fixed. Increase the stitch length to maximum, set the tension below 2 and baste the remaining length of the fabric.

Press open the seam allowance. Place the zipper face down on the seam allowance with the teeth against the seam line. Baste the zipper tape in place.

- ① Wrong side
- ② 2cm
- ③ 5mm
- ④ Basting
- ⑤ Reverse stitches

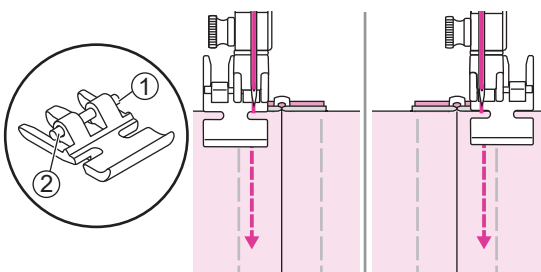

Attach the zipper foot.

- ① Attach the right pin for sewing the left side of the zipper.
- ② Attach the left pin for sewing the right side of the zipper.

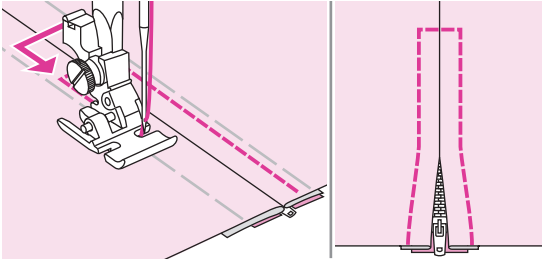

Stitching around the zipper. Remove the basting and press.

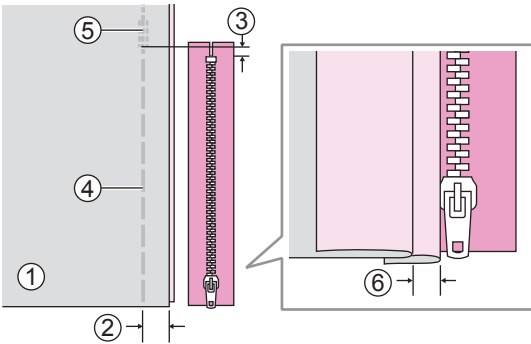

Inserting a side zipper

Place the right sides of the fabric together. Sew a bottom seam 2cm from the right edge of the zipper bottom stop position. Sew few reverse stitches for fixed. Increase the stitch length to maximum, set the tension below 2 and baste the remaining length of the fabric.

Fold back to the left the seam allowance. Turn under the right the seam allowance to form a 3mm fold.

- ① Wrong side
- ② 2cm
- ③ 5mm
- ④ Basting
- ⑤ Reverse stitches
- ⑥ 3mm

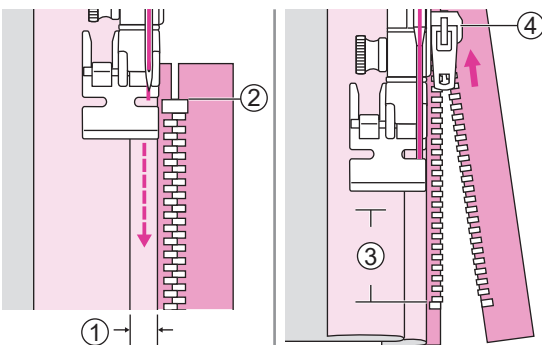

Attach the zipper foot. Attach the right pin for sewing the left side of the zipper. Sew the zipper to the piece of fabric with the extra 3mm, starting from the end of the zipper.

Stop the machine about 5cm from the top of the zipper. Lowered the needle into the fabric, raise the presser foot lifter, and then open the zipper and continue sewing.

- ① 3mm
- ② The end of zipper
- ③ 5cm
- ④ Zipper

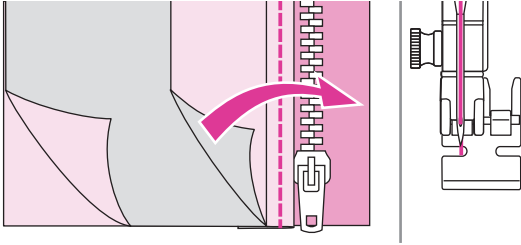

Turn the fabric right side out. Attach the left pin for sewing the rightside of the zipper.

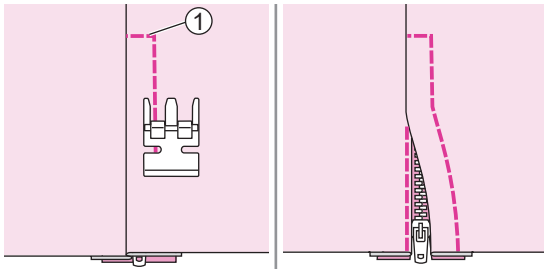

Stitch across the lower end and the right side of the zipper.

① Lower end

Stop the machine about 5cm from the top of the zipper. Remove the basting and open the zipper. Stitch the remaining of the seam.

Satin stitch sewing

Use the satin stitch foot for satin stitching and sewing decorative stitches.

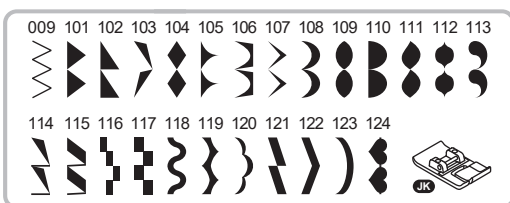

Using the satin stitch foot.

Note

When sewing very lightweight fabrics, it is recommended that you use interfacing or stabilizer on the wrong side of the fabric.

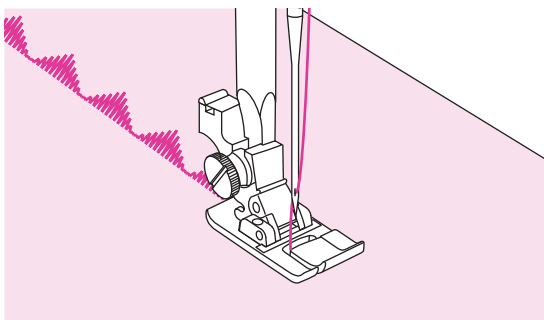

This foot has a groove on the underside which allows dense stitching to pass freely underneath.

To sew the satin or decorative stitch, you may adjust the length and width of the stitch. Experiment with fabric scraps until you get the desired length and width.

Gathering

The Gathering Foot is used for gathering fabrics. Ideal for clothing as well as home decor. It works best on thin to medium weight fabrics.

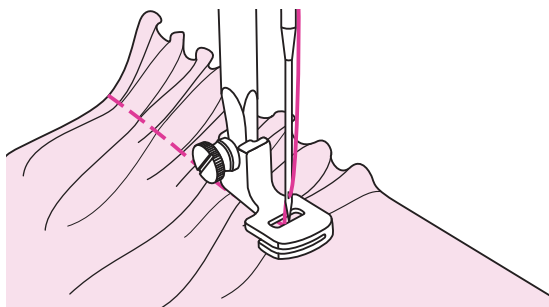

Using the gathering foot.

Gathered fabric

Remove the presser foot holder and attach the gathering foot, set the tension below 2. Place fabric to be gathered under presser foot to the right of the presser foot.

Sew a row of stitching, keeping the raw edge of fabric aligned with the right edge of foot. The stitches automatically cause the fabric to gather.

Suitable for light to medium weight fabrics. If your fabric is light, such as batiste or lace, you will have more gathers.

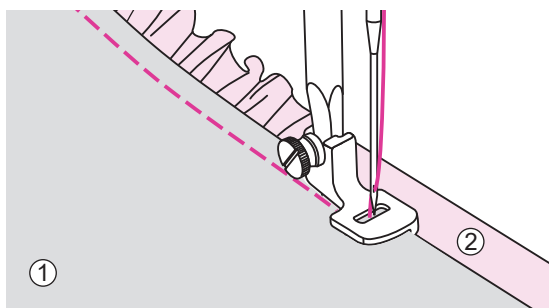

To gather and attach gathered fabric in one step

Look closely at the gathering foot to see a slot on the bottom. When using the slot, you can gather the bottom layer of the fabric while attaching it to a flat top layer, such as the waistband on a dress bodice.

Remove the presser foot holder and attach gathering foot. Place the fabric to be gathered with right side up under the foot. Place top layer of the fabric right side down in the slot. Guide the two layers as illustrated. Turn the top layer of fabric right side out.

- ① Top layer of fabric (wrong side)
- ② Bottom layer of fabric (right side)

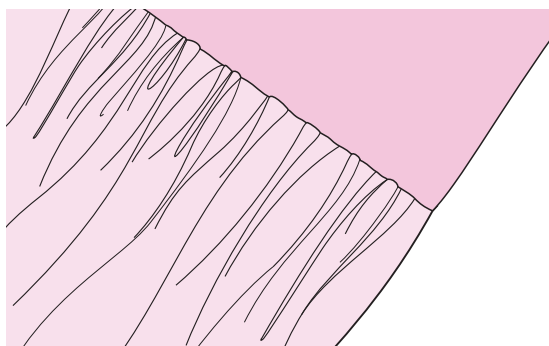

Note

- Please use the same fabric of the project and do a sewing test in advance. When testing machine for adjustments to achieve desired fullness, work with 25cm of the fabric, trims or elastic. This makes it easier to determine the adjustments and how much change is needed for your project
- Sew slow to medium speed for better fabric control.

Smocking

The decorative stitch created by stitching or embroidering over gathers is called "smocking". It is used to decorate the front of blouses or cuffs. The smocking stitch adds texture and elasticity to the fabric.

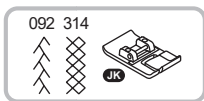

Using the satin stitch foot.

Increase the stitch length to maximum, set the tension below 2 and basting lines 1cm across the area to be smocked.

- ① 1cm
- ② Basting

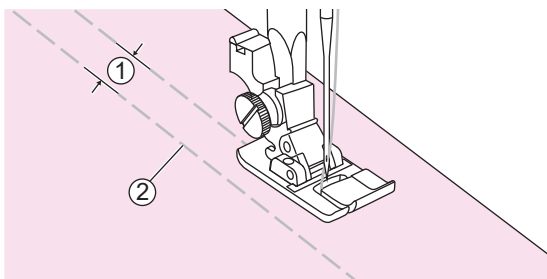

Knot the threads along one edge.

Pull the bobbin threads and distribute the gathers evenly. Secure the threads at the other end.

- ① Bobbin thread

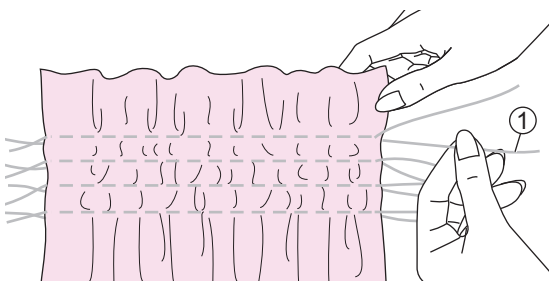

Reduce the tension if necessary and sew decorative stitches between the straight seams.

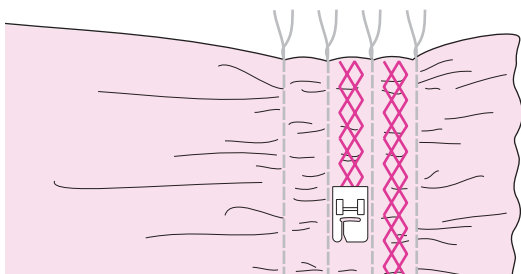

Pull out the basting.

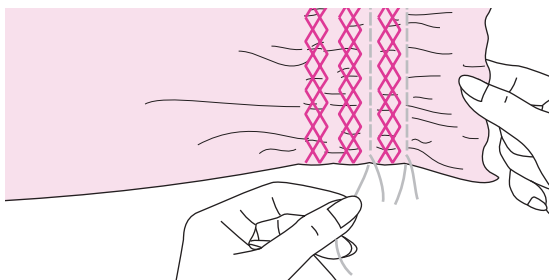

Free motion darning, embroidery and monogramming

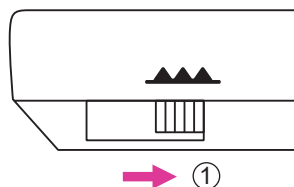
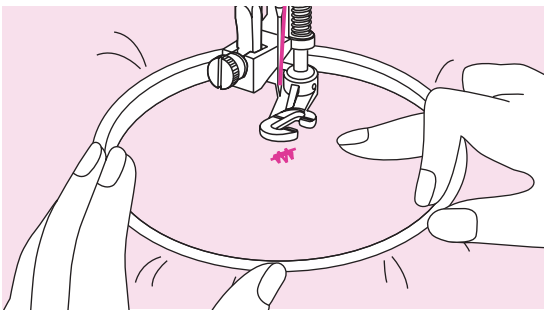
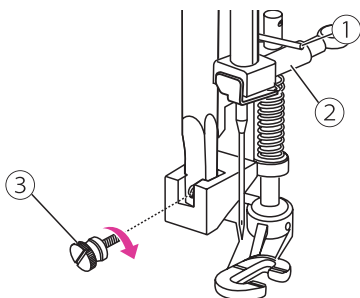
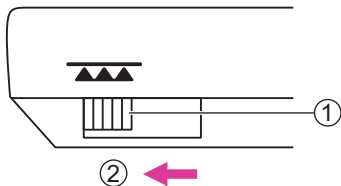
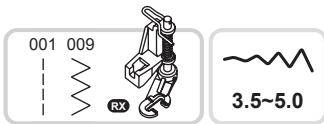

Preparation for embroidering and monogramming

* Embroidery hoop is not included with the machine.

Using the darning/embroidery foot.

Move the drop feed lever to lower the feed dogs.

- ① Drop feed lever
- ② Lowered position

Remove the presser foot holder and attach the darning/embroidery foot. The lever should be behind the needle clamp screw. Press the darning/embroidery foot on firmly from behind with your index finger and tighten the screw.

- ① Lever
- ② Needle clamp screw
- ③ Screw

Draw the desired lettering or design on the surface of the fabric.

Stretch the fabric between the embroidery hoop as firmly as possible.

Place the fabric under the needle. Make sure the presser foot bar is down to its lowest position.

Turn the handwheel towards you to bring up the bobbin thread through the fabric. Sew a few securing stitches at the starting point.

Hold the hoop with thumb and forefinger of both hands while pressing the material with the middle and third finger and supporting the outside of the hoop with your small finger.

△ Attention

Keep fingers away from moving parts, especially needles.

Note

When you finish the work, move the drop feed lever to raise the feed dogs.

- ① Raised position

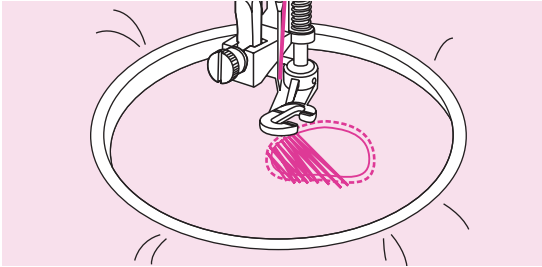

Darning

First sew around the edges of the hole to secure the threads. Working from left to right, sew over the hole in a constant and continuous movement.

Turn the work by 1/4 and sew over the first stitching moving the work slower over the hole to separate the threads and not form big gaps between the threads.

Note

Free motion darning is accomplished without the sewing machine internal feed system. Movement of the fabric is controlled by the operator. It is necessary to coordinate sewing speed and movement of fabric.

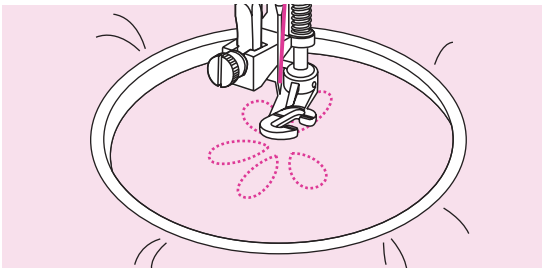

Embroidery

Stitch along the outline of the design by moving the embroidery hoop. When sewing, make sure to maintain a constant speed.

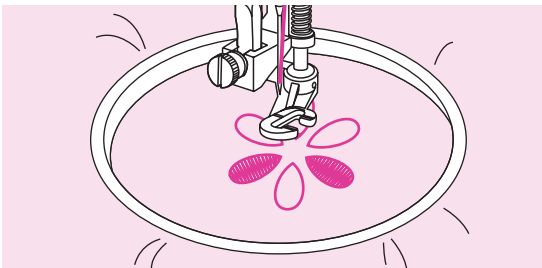

Fill in the design working from the outline towards the inside. Keep the stitches close together.

You will get longer stitches by moving the hoop faster and shorter stitches by moving the hoop slower.

Secure with reinforcement stitches at the end of the design.

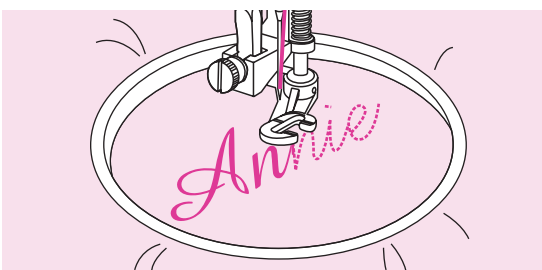

Monogramming

Sew at constant speed, moving the embroidery hoop slowly along the lettering.

When the letter is finished, secure with reinforcement stitches at the end of the design.

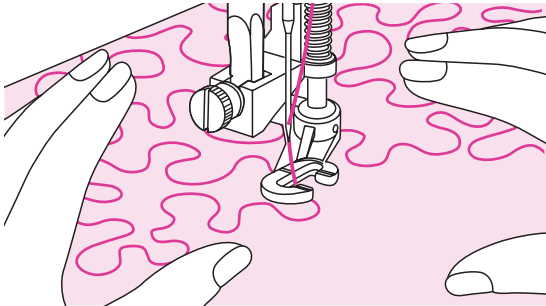
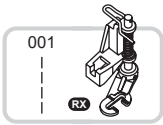

Using the darning/embroidery foot.

Free motion

Adjust the upper thread tension and the balance to the sewing project if necessary.

Slowly press down the foot control or press the start/stop button to start sewing.

Hold both hands close to the presser foot like an embroidery hoop to guide the fabric.

If the thread is lying on top of the fabric, slow down the movement. If there are knots on the wrong side of the fabric, move the fabric more quickly.

Open toe foot

This foot makes quick work of appliqués and embroidery projects, as well as the sewing over of lines and patterns. The open shape ensures a clear view of the seam, and is therefore ideal for sewing on tapes and ribbon.

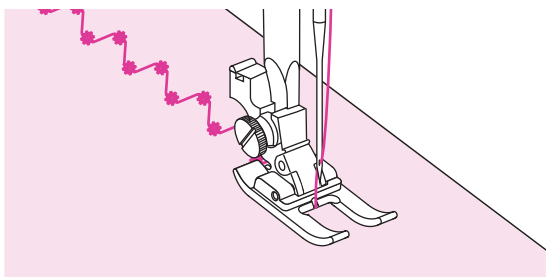
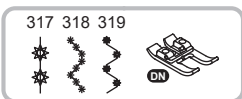

Using the Open toe foot.

Set the machine to the desired decorative stitch and begin to sew.

Quilting

Sandwich batting between the top and bottom layers of fabric is call "Quilting". The top layer is usually formed by multiple geometrically shaped pieces of materials joined together.

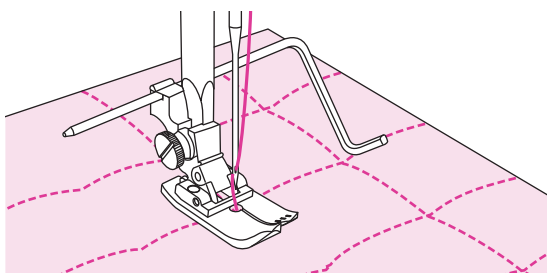
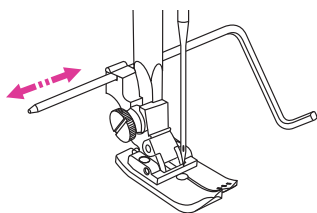
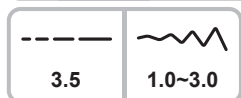
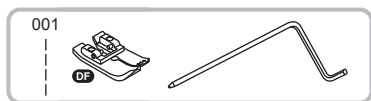

Using the Quilting foot with edge/quilting guide.

⚠ Attention

Only center straight stitches are applicable while using quilting foot.

Using the edge/quilting guide

Attach the edge/quilting guide in the presser foot holder as illustrated and set the space as you desire.

Sew the first row and move over the fabric to sew successive rows with the guide riding along the previous row of stitching.

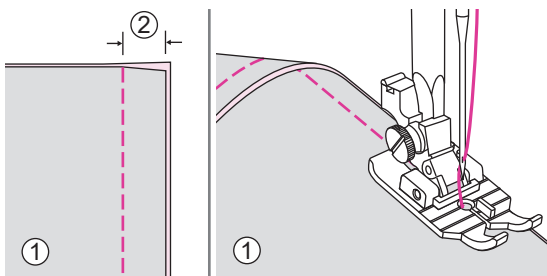

Using the 1/4" quilting foot.

Joining the pieces of the fabric

Use the right edge of the presser foot as a guide for a 1/4" seam. There are markings on the foot which serve as 1/4" and 1/8" pivot points, both in front and behind the needle.

Place fabric under the 1/4" quilting foot and lower the presser foot lever. Sew while keeping the fabric edge(s) lined up evenly with the right edge of the presser foot. To pivot, when the edge of the fabric reaches the foot's 1/4" turning mark (the first marking toward the front of the foot), leave the needle down in the fabric, pivot the fabric and continue sewing the next 1/4" seam.

- ① Wrong side
- ② 5mm

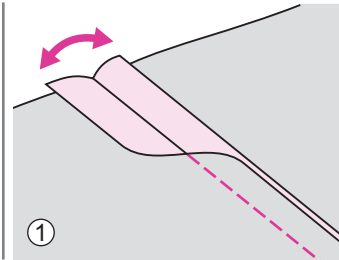
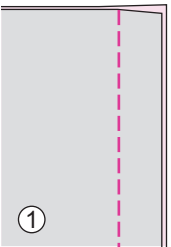
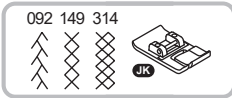
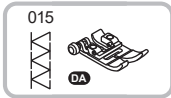

Using the all purpose foot or satin stitch foot.

Patchwork stitching

Place the two fabrics, right sides together and sew using a straight stitch.

Open the seam allowance and press it flat.

① Wrong side

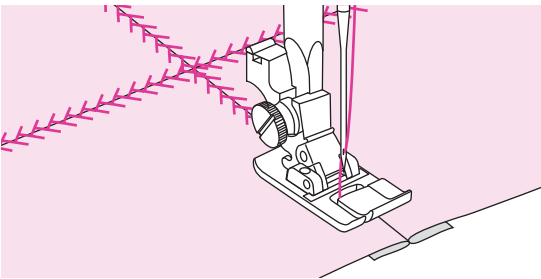

Working on the right side of the fabric, place the center of the presser foot on the seam line of the joined fabrics and stitch over the seam.

Non-stick foot

Due to the special coating on the bottom of this foot, it's perfect for sewing hard-to-feed fabrics, like leather, foam, plastic, imitation leathers and plastic-coated fabrics, such as leather or vinyl.

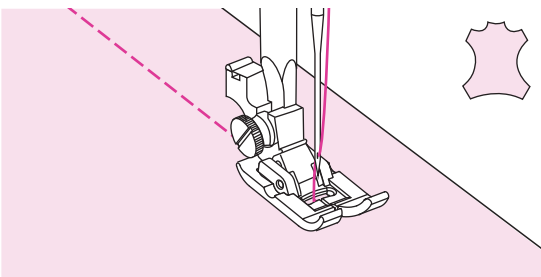
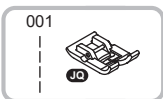

Using the non-stick foot.

Select desired stitch.

Sew slowly and guide the layers.

Applique

You can create and applique by cutting a different piece of fabric into a shape and using it as a decoration.



Using the all purpose foot.

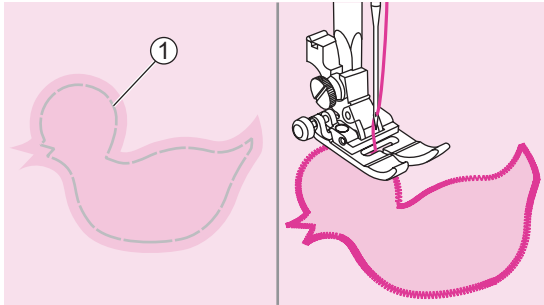

Cut out the applique design and baste it on the fabric. Sew slowly around the edge of the design.

① Basting

Trim the excess material outside the stitching. Make sure not to cut any stitches. Remove the basting.

Fagoting

Stitching across an open seam is called "fagoting". It is used on blouses and children's clothing. This stitch is more decorative when thicker thread is used.

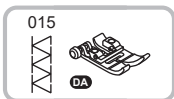

Using the all purpose foot.

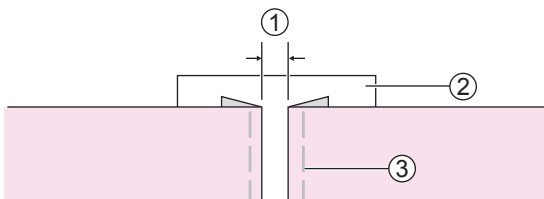

Separate the folded edges of the fabric pieces with a gap of 4mm and baste them onto a piece of thin paper or water-soluble stabilizer sheet.

① 4mm

② Thin paper or water-soluble stabilizer

③ Basting

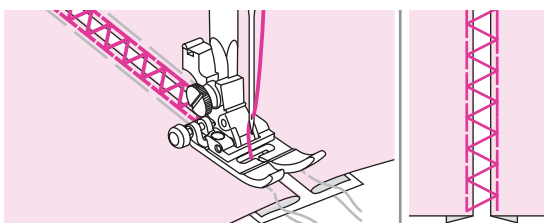

Align the center of the presser foot with the center of the two pieces of fabric and begin sewing.

After sewing, remove the stabilizer and basting.

Scallop stitch

The wave-shaped repeating stitch, that looks like shells, is called "scalloping". It is used to decorate the collar of blouses and the edges of knitting projects.

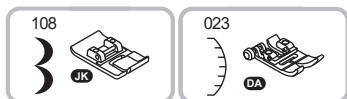

Using the satin stitch foot or all purpose foot.

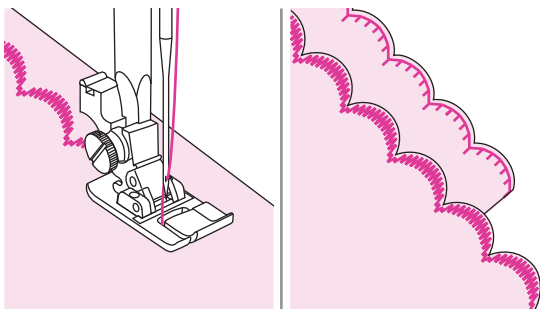

Scallop edging

Stitch along the edge of the fabric, making sure not to sew directly on the edge of the fabric.

For better results, apply spray starch onto the fabric and press with a hot iron before it is sewn.

Trim the fabric close to the stitching taking care not to cut the stitches.

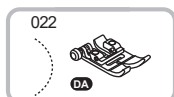

Using the all purpose foot.

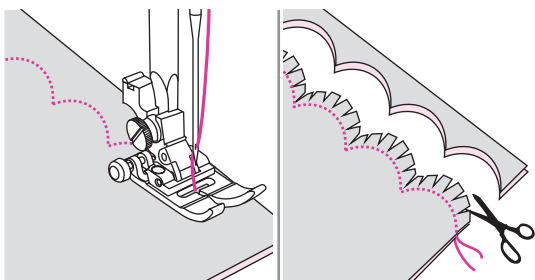

Scallop hem

Fold the fabric right side together. Sew along the folded edge as illustrated.

Cut the fabric along the seam leaving an allowance of 3mm for seaming.

Notch the allowance.

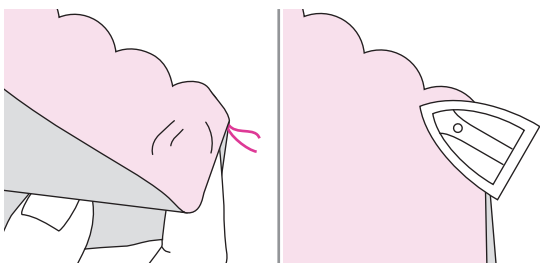

Turn the fabric over and push out the curved seam to the surface and iron it.

Cording

Used for embellishing 1 to 3 cords or decorative threads. Sew over one strand of cording to create a pretty swirled design on a jacket or vest or sew over three strands of cording for border trims. Pearl cotton, knitting yarn, embroidery floss, lace thread, fine wool or lily yarn can be used for cording.

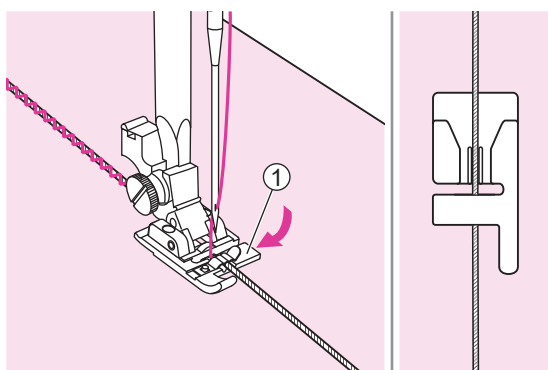
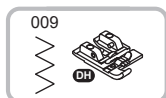

Using the cording foot.

Single cording

Mark the design on the fabric. Insert the cord in the center groove of the cording foot from the right side opening.

① Right side opening

Place the cord under the groove of the cording foot and pull the cord about 5cm behind the foot.

The grooves under the foot will hold the length of the cord in place while the stitches are being formed over the cord.

Select the stitch and adjust the stitch width so that the stitches are just covering the cord. Lower the presser foot lifter and sew slowly, guiding the cord over the design.

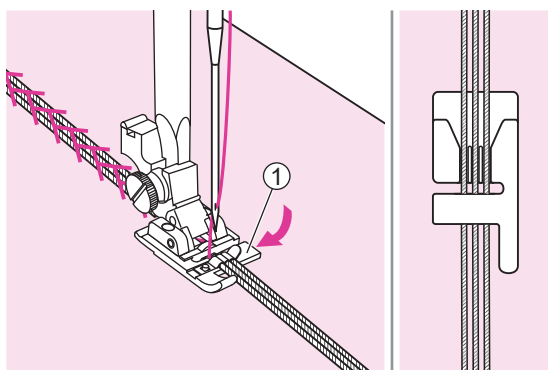
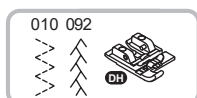

Using the cording foot.

Stripe cording

Mark the design on the fabric. Insert the cord in the center groove of the cording foot from the right side opening.

① Right side opening

Place three cords under the grooves of the cording foot and pull the cord about 5cm behind the foot.

The grooves under the foot will hold the length of the cord in place while the stitches are being formed over the cord.

Select the stitch and adjust the stitch width so that the stitches are just covering the cord. Lower the presser foot lifter and sew slowly, guiding the cord over the design.

Narrow hemming

The hemmer foot is used to stitch the narrow rolled hems usually found on shirt tails, table linens and along the edge of frills.

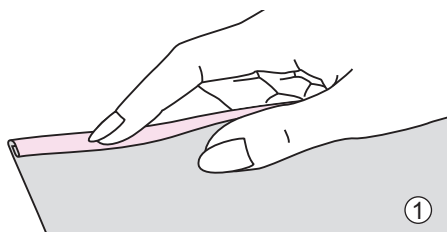

Using the hemmer foot.

Fold edge of fabric over about 3mm, then fold it over again 3mm for about 5cm along the edge of the fabric.

① Wrong side

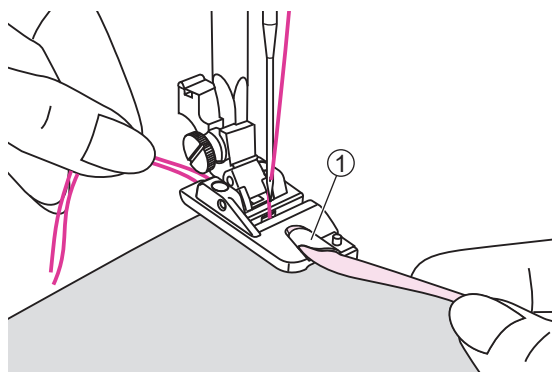

Insert the needle into the fold by turning the handwheel toward you, and lower the presser foot lifter. Sew several stitches and raise the presser foot lifter.

Insert the fabric fold into the spiral opening of hemmer foot. Move fabric back and forth until the fold forms a scroll shape.

① Scroll shape of the hemmer foot

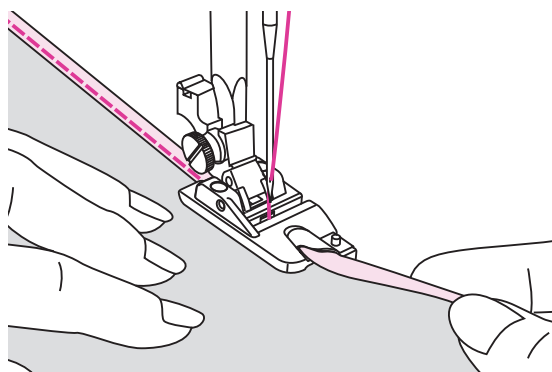

Lower the presser foot lifter and start sewing slowly guiding the raw edge of the fabric in front of the hemmer foot evenly into the scroll of the foot.

Invisible zipper application

The invisible zipper foot provides an invisible closing on skirts, dresses and a variety of garments and accessories.

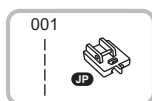

Using the invisible zipper foot.

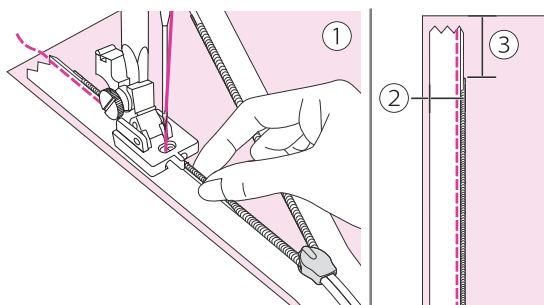

Attach the invisible zipper foot to the machine, with the needle lined up with center mark. Place open zipper face-down on right side of fabric as shown. Pin in place with coil on seam line (1.6cm) and top stop 1.9cm below raw edge of garment. With right-hand groove of foot over coil, stitch zipper until the foot hits the slider (remove pins as you come to them.) Back-tack.

- ① Right side
- ② 1.6cm
- ③ 1.9cm

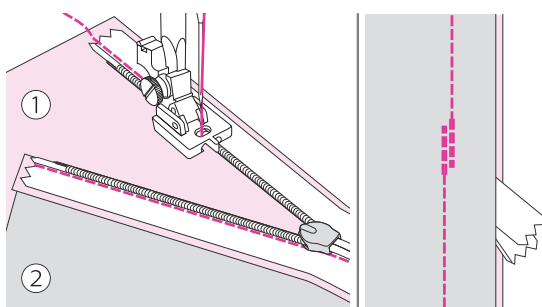

To attach the other half of the zipper, pin tape face-down with coil on seam line (1.6cm) and top stop 1.9cm below raw edge of garment, as before. Make sure that the zipper is not twisted at the bottom. Use the left-hand groove of foot, making sure that the center marking is still lined up with the needle and stitch, as before.

Close zipper. Slide zipper foot to the left so that needle is in the outer notch. Pin the seam together below zipper opening. Fold end of zipper out of the way and lower the needle by hand slightly above and to the left of the last stitch.

Stitch seam for about 5 cm, as shown. Pull thread through to one side and tie. Change to regular presser foot and complete the seam.

At zipper end, stitch about 2.5cm of each zipper tape to seam allowance only.

- ① Right side
- ② Wrong side

Twin needle

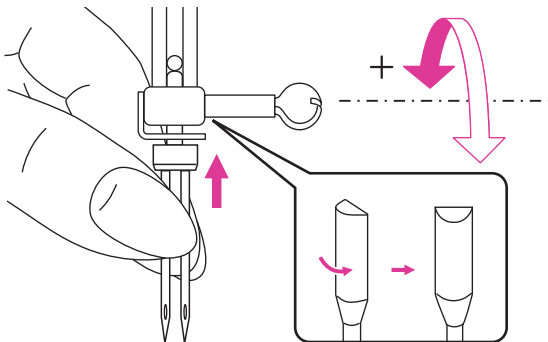

When using twin needles, be sure to attach the suggested presser foot which screen appears.

Insert the twin needle. Please refer to "Replacing the needle" chapter for more information.

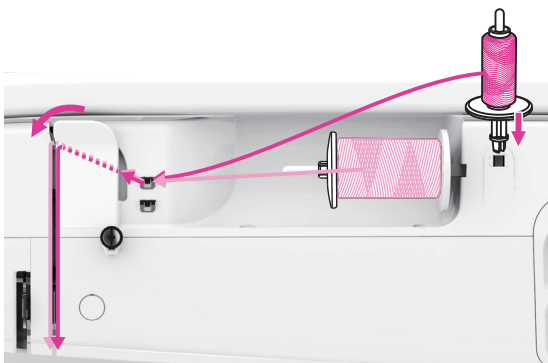

Set the second spool pin into the hole on the top of the machine and put spool pin felt and thread onto second spool holder.

Threading twin needle is the same instruction as single needle. Please refer to "Threading the upper thread" chapter for more information.

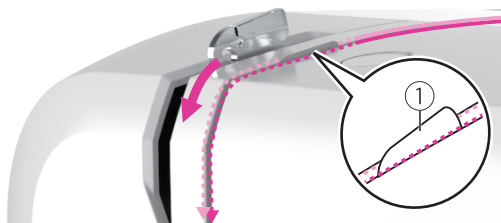

⚠ Attention

The thread from horizontal spool holder must through from left side of the guide plate and the second spool holder thread pass through from right side of the guide plate.

① Twin needle thread guide plate

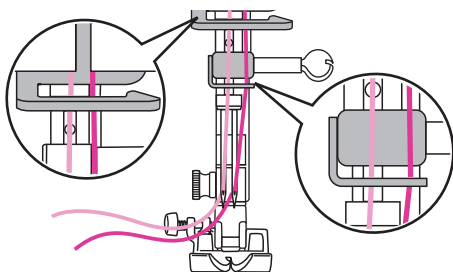

As shown in the picture, pull the thread from the horizontal spool holder pass through left needle hole manually and thread from the second spool holder pass through right needle hole.

Note

- Twin needle can not use automatic needle threader.
- Make sure that the two threads used to thread the twin needle are of the same weight. You can use one or two colors.

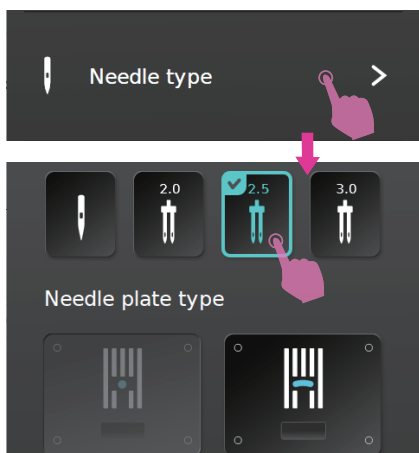

Twin needle setting

Enter the needle type setting page, select the twin needle size to use. The machine automatically reduces the maximum width for the twin needle sewing.

⚠ Attention

- Be sure to set the twin needle mode when using the twin needle. Using the twin needle in the single needle mode may cause the needle to break, resulting in damage.
- If you use the straight needle plate after setting the twin needle, a warning message will pop up in the screen, and the machine will automatically set to the single needle mode, and please replace the single needle, otherwise it will cause the needle to break and cause danger.

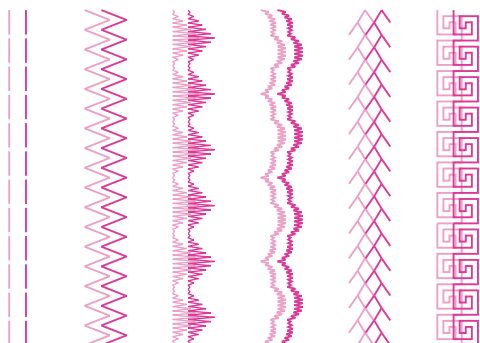

Two lines of stitching are sewn parallel to each other.

Note

- When sewing with twin needle, always proceed slowly, and make sure to maintain a low speed to insure quality stitching.
- When twin needle sewing has been selected, it will remain active even the stitch is changed.

⚠ Attention

After finishing sewing, please remember to change from twin needle to single needle and go to setting page to select the single needle mode.



Maintenance and Trouble Shooting

Maintenance

⚠ Attention

Disconnect the power cord from the wall socket before carrying out any maintenance, otherwise injury or electrical shock may result.

Clean the machine surface

If the surface of the sewing machine is dirty, lightly soak a cloth in mild detergent, squeeze it out firmly and then wipe the surface. After cleaning it once in this way, wipe the surface again with a dry cloth.

Do not use any organic solvents or detergents.

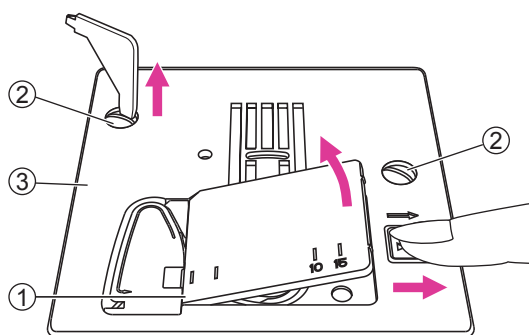

Clean the hook

If lint and bits of thread accumulate in the hook, this will interfere with the smooth operation of the machine. Check regularly and clean the stitching mechanism when necessary.

Remove the needle, presser foot and presser foot holder.

Remove the bobbin cover and bobbin.

Remove the screws on the needle plate then remove the needle plate.

- ① Bobbin cover
- ② Screws
- ③ Needle plate

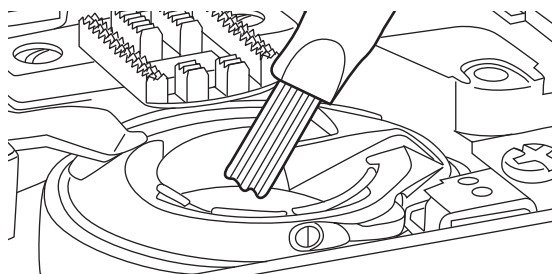

Clean the feed dogs and bobbin case with a brush. And also use a soft and dry cloth to clean them.

Warning Function



Warning beeping sound

- Operate correctly: 1 beep.
- Operate incorrectly: 3-short beeps.
- When the sewing machine is in trouble and can't sew: 1-long beep.

It means that the thread may be twisted or jammed and the handwheel axle can't move. Please look through the "Trouble shooting guide" to find the solution. After the problem has been solved, the machine will be able to sew.

Note

If the problem is still not solved, please contact your local dealer.

⚠ Attention

During sewing, if the thread has been jammed inside the hook and needle movement stops. If you continue to sew, the machine will stop automatically due to safety. If machine stops, please turn off the machine firstly then turn on again.

Trouble shooting guide

Before calling for service, check below trouble shooting guides in advance, if problem still exist, please contact nearest dealer or local service center.

| Problem | Cause | Correction |
|----------------------|---|---|
| Upper thread breaks | 1. The machine is not threaded correctly. | 1. Rethread the upper thread. |
| | 2. The thread tension is too tight. | 2. Reduce the thread tension (to lower number). |
| | 3. The thread is too thick for the needle. | 3. Select a larger needle size. |
| | 4. The needle is not inserted correctly. | 4. Remove and reinsert the needle (flat side towards the back). |
| | 5. The thread is wound around the spool holder pin. | 5. Remove the reel and wind up the thread onto the reel. |
| | 6. The needle is damaged. | 6. Insert a new needle. |
| Bobbin thread breaks | 1. The bobbin case is not inserted correctly. | 1. Remove and reinsert the bobbin case and pull on the thread. |
| | 2. The bobbin case is threaded wrong. | 2. Check both bobbin and bobbin case if on the correct position. |
| Skipped stitches | 1. The needle is not inserted correctly. | 1. Remove and reinsert the needle (flat side towards the back). |
| | 2. The needle is damaged. | 2. Insert a new needle. |
| | 3. The wrong size needle has been used. | 3. Choose a needle to suit the thread. |
| | 4. The presser foot is not attached correctly. | 4. Check and attach it correctly. |
| | 5. The machine is not threaded correctly. | 5. Rethread the upper thread. |
| Needle breaks | 1. The needle is damaged. | 1. Insert a new needle. |
| | 2. The needle is not correctly inserted. | 2. Insert the needle correctly (flat side towards the back). |
| | 3. Wrong needle size for the fabric. | 3. Choose a needle to suit the thread and fabric. |
| | 4. The wrong presser foot is attached. | 4. Select the correct presser foot. |
| | 5. The needle clamp screw is loose. | 5. Use the screwdriver to tighten the screw. |
| | 6. The presser foot is not appropriate for the type of stitch that you sew. | 6. Attach appropriate presser foot for the type of stitch that you sew. |
| | 7. The upper thread tension too tight. | 7. Loosen the upper thread tension. |

| Problem | Cause | Correction |
|------------------------------|---|--|
| Loose stitches | 1. The machine is not correctly threaded. | 1. Check the threading and rethread. |
| | 2. The bobbin case is not threaded correctly. | 2. Thread the bobbin case as illustrated. |
| | 3. Needle/fabric/thread combination is wrong. | 3. The needle size must suit the fabric and thread. |
| | 4. The thread tension is wrong. | 4. Correct the thread tension. |
| Seam gather or pucker | 1. The needle is too thick for the fabric. | 1. Select a correct needle size. |
| | 2. The stitch length is wrong. | 2. Adjust the stitch length. |
| | 3. The thread tension is too tight. | 3. Loosen the thread tension. |
| Seam puckering | 1. The needle thread tension is too tight. | 1. Loosen the thread tension. |
| | 2. The needle thread is not threaded correctly. | 2. Rethread the machine. |
| | 3. The needle is too heavy for the fabric being sewn. | 3. Choose a needle to suit the thread and fabric. |
| | 4. The stitch length is too long for the fabric. | 4. Adjust the stitch length shorter. |
| | 5. Sewing on thin fabric. | 5. Sew with a stabilizer material under the fabric. |
| Patterns are distorted | 1. The presser foot is not suited for the pattern. | 1. Select the correct foot. |
| | 2. The needle thread tension is too tight. | 2. Loosen the thread tension. |
| Thread has jammed | 1. Thread is caught in the hook. | Remove the upper thread and bobbin case, turn the handwheel backwards and forwards and remove the thread remnants. |
| | 2. The feed dogs are packed with lint. | |
| The machine is noisy | 1. Fluff or oil have collected on the hook or needle bar. | 1. Clean the hook and feed dog. |
| | 2. The needle is damaged. | 2. Insert a new needle. |
| | 3. Thread is caught in the hook. | Remove the upper thread and bobbin case, turn the handwheel backwards and forwards and remove the thread remnants. |
| | 4. The feed dogs are packed with lint. | |
| Uneven stitches, uneven feed | 1. Poor quality thread. | 1. Select a better quality thread. |
| | 2. The bobbin case is threaded uncorrect. | 2. Remove the bobbin case and the thread and reinsert them correctly. |
| | 3. Fabric has been pulled on. | 3. Do not pull on the fabric while sewing, let it be taken up by the machine. |

| Problem | Cause | Correction |
|------------------------------------|---------------------------------------|---|
| The sewing machine doesn't operate | 1. The machine is not turned on. | 1. Turn on the machine. |
| | 2. The presser foot lifter is raised. | 2. Lower the presser foot lifter. |
| | 3. The machine is not plugged in. | 3. Connect the power cord to the electric outlet. |



Do not dispose of electrical appliances as unsorted municipal waste, use separate collection facilities.

Contact your local government for information regarding the collection systems available.

If electrical appliances are disposed of in landfills or dumps, hazardous substances can leak into the groundwater and get into the food chain, damaging your health and well-being.

When replacing old appliances with new ones, the retailer is legally obligated to take back your old appliance for disposal at least for free of charge.

